

Lecture Note 9. Paging and Beyond Physical Memory

June 20, 2021
Jongmoo Choi

Dept. of Software
Dankook University

<http://embedded.dankook.ac.kr/~choijm>

(This slide is made by Jongmoo Choi. Please let him know when you want to distribute this slide)

Contents

- From Chap 18~22 of the OSTEP
- Chap 18. **Paging**: Introduction
 - ✓ Page Table
 - ✓ Address Translation and Memory Trace
- Chap 19. **TLB** (Translation Lookaside Buffer)
 - ✓ Faster Translation
 - ✓ TLB hit: Fast translation vs TLB miss: TLB management
- Chap 20. Advanced Page Tables
 - ✓ **Multi-level Page Table**
 - ✓ Inverted Page Table
- Chap 21. **Beyond Physical Memory**: Mechanism
 - ✓ Memory Hierarchy and on-demand loading
 - ✓ Swap and Page Fault
- Chap 22. **Beyond Physical Memory**: Policies
 - ✓ Cache management model: **Locality**, Trashing
 - ✓ Page replacement policies: FIFO, LRU, OPT, Approximate LRU, ...

Executive Summary

- Comparison among **contiguous**, segmentation and paging
 - ✓ Contiguous allocation: based on base, limit register
 - ✓ Non-contiguous allocation
 - Segmentation: variable size
 - Paging: fixed-size

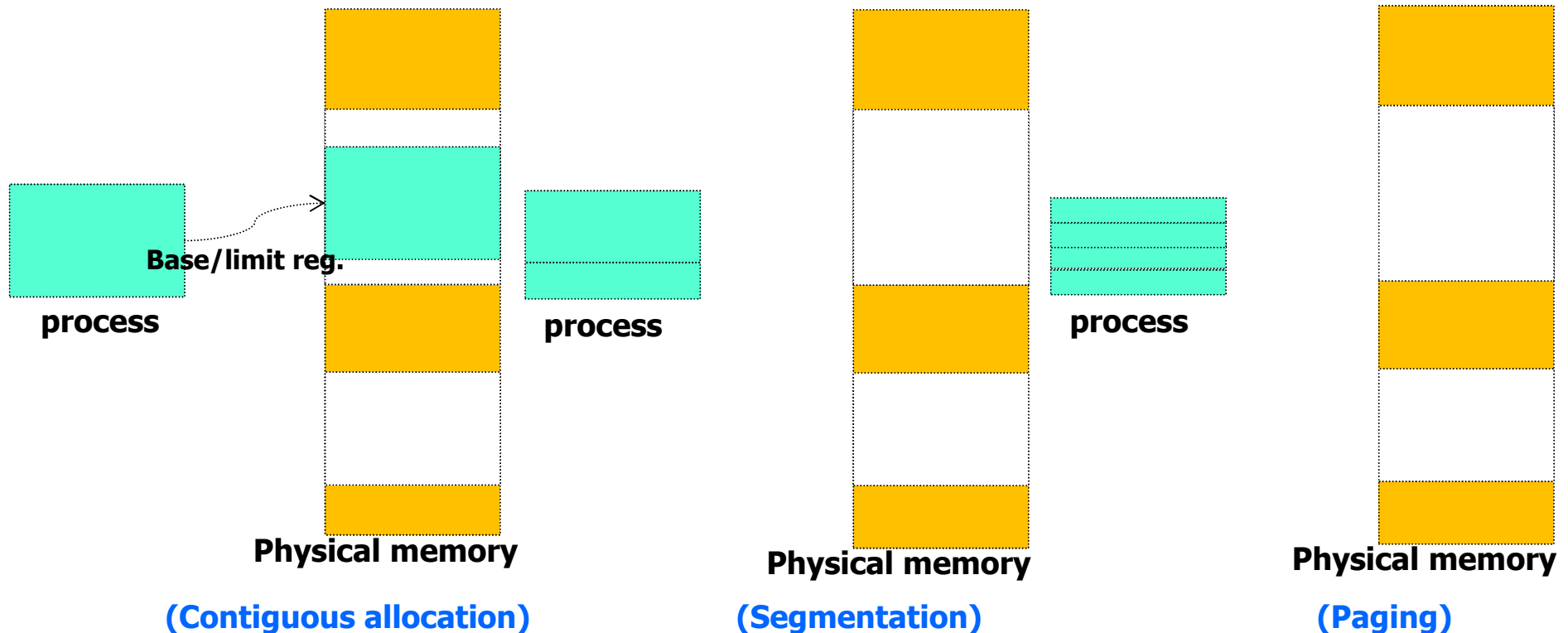

Executive Summary

- Comparison among contiguous, **segmentation** and paging
 - ✓ Contiguous allocation: based on base, limit register
 - ✓ Non-contiguous allocation
 - Segmentation: variable size
 - Paging: fixed-size

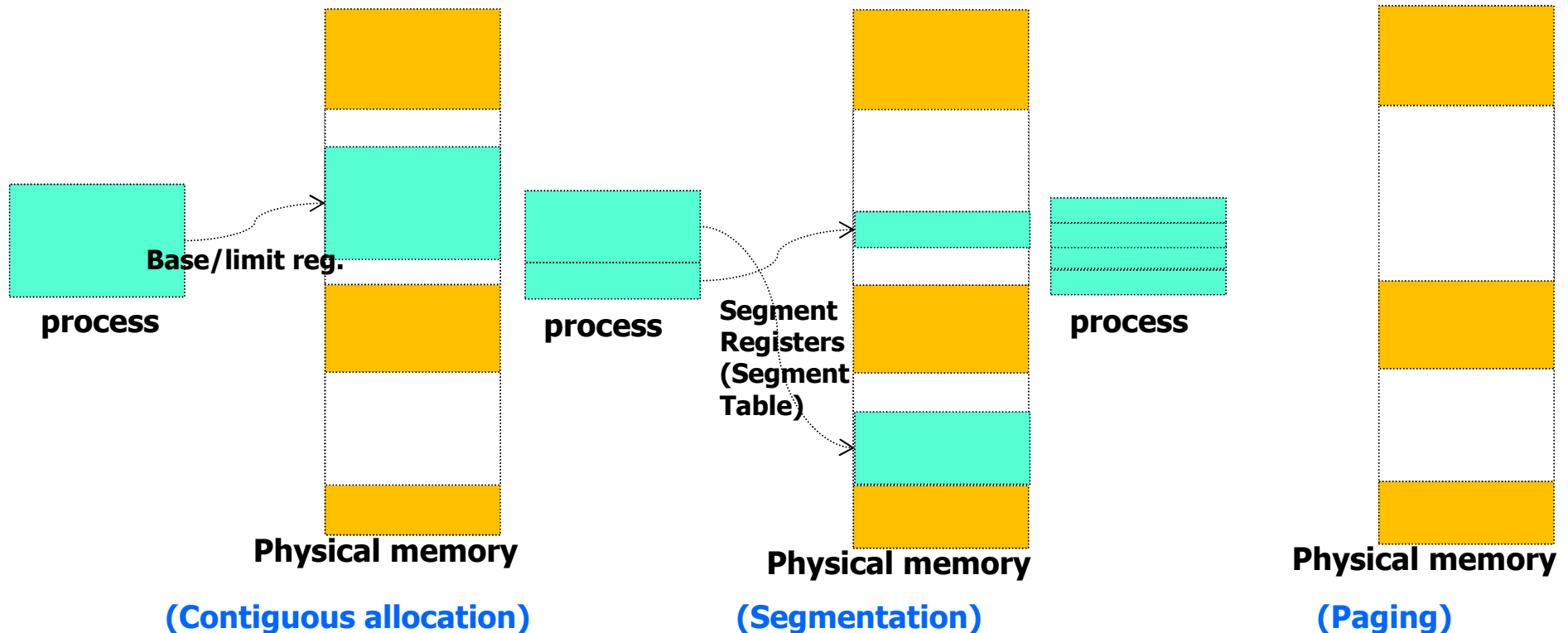

Executive Summary

- Comparison among contiguous, segmentation and paging
 - ✓ Contiguous allocation: based on base, limit register
 - ✓ Non-contiguous allocation
 - Segmentation: variable size
 - Paging: fixed-size

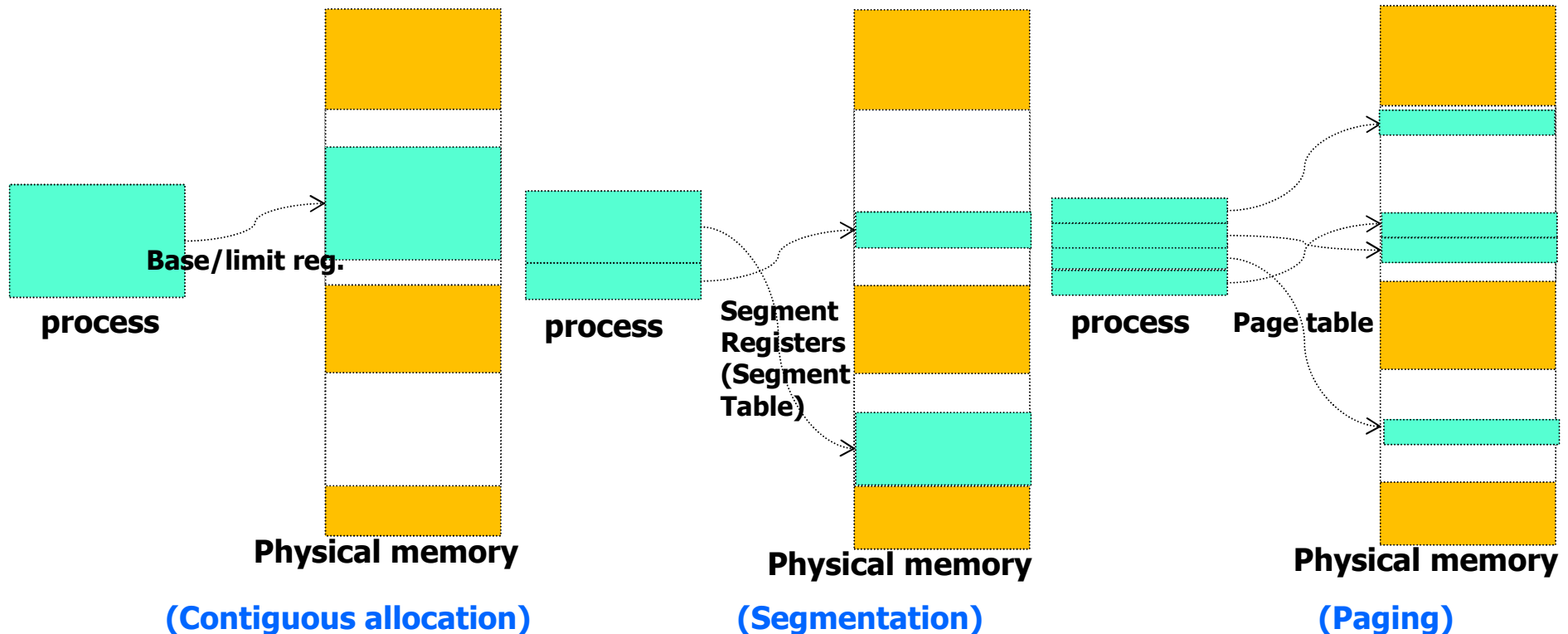

Chap 18. Paging: Introduction

■ Why paging?

- ✓ Two common approaches for non-contiguous management
 - Variable size: segmentation
 - Sharing, Protection support
 - Address translation: using **segment table**
 - But, memory becomes fragmented (external fragmentation), thus allocation becomes more challenging over time
 - Fixed size: paging
 - No external fragmentation, Easy for HW supports (e.g. TLB)
- ✓ Terms for paging
 - Virtual memory: divided into a fixed size unit called **page**
 - Physical memory: also divided into a fixed size unit called **page frame**
 - Address translation: using **page table**

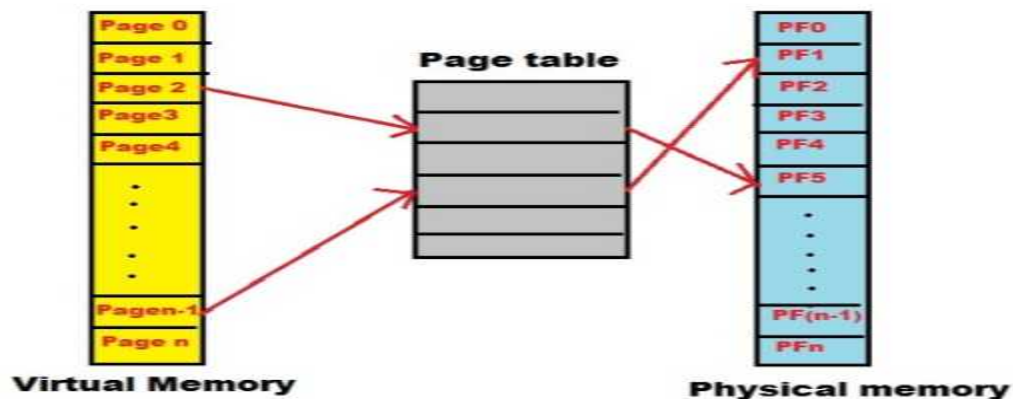

18.1 A simple example and overview

■ Example of Paging

- ✓ Virtual memory
 - Tiny address space of a process: 64B total size, page size: 16B → 4 pages in an address space
- ✓ Physical memory
 - Tiny physical memory: 128B, page frame size: 16B → total 8 frames
 - Frame 0 for OS itself
 - Frame 2, 3, 5 and 7 for the process (Note that they are not contiguous and not in order)
 - Other frames are managed by a free list (a bitmap or list is enough)

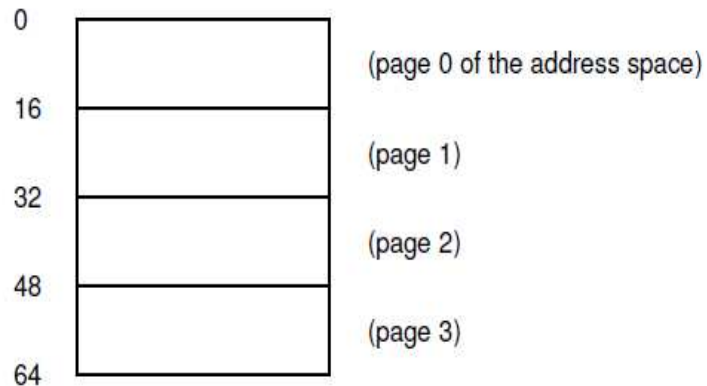

Figure 18.1: A Simple 64-byte Address Space

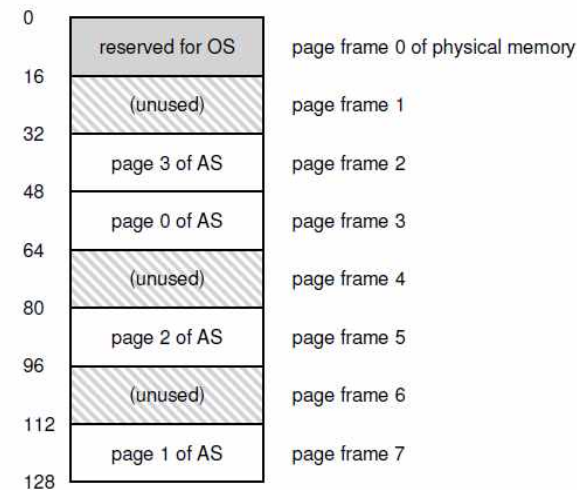

Figure 18.2: A 64-Byte Address Space In A 128-Byte Physical Memory

18.1 A simple example and overview

■ Page table

- ✓ A data structure that records where each page is placed in physical memory (which frame): same role as segment table
- ✓ Per-process data structure
- ✓ Used for address translation
 - Virtual address: 4 → physical address: $3 \times 16\text{B} + 4 = 52$
 - Virtual address: 44 → physical address: $5 \times 16\text{B} + 12 = 92$
 - Virtual address: 21 → physical address: $7 \times 16\text{B} + 5 = 117$

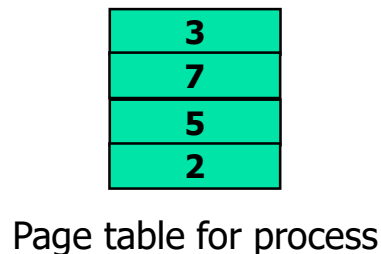
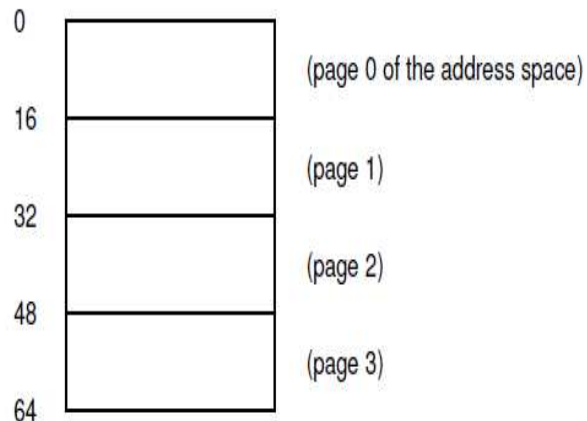

Figure 18.1: A Simple 64-byte Address Space

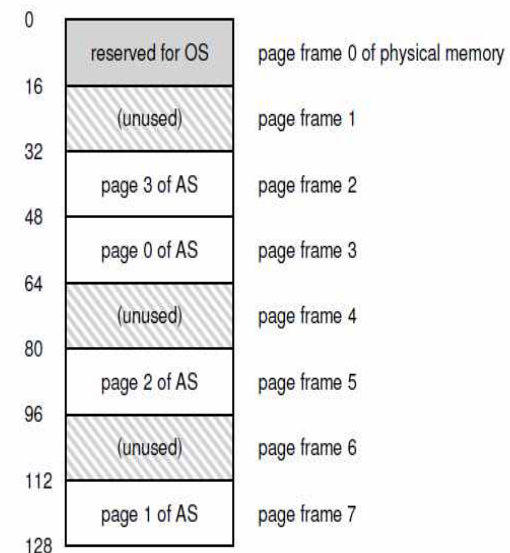

Figure 18.2: A 64-Byte Address Space In A 128-Byte Physical Memory

Note: all pages are not required to locate in physical memory → demand paging (chap. 21)

18.1 A simple example and overview

■ Address translation in formal

- ✓ Address size
 - Address space size: 64B → virtual address size: 6-bit ($2^6 = 64B$)
 - c.f.) Address space size of 32-bit CPU: 4GB → address size: 32-bit ($2^{32} = 4GB$)
 - Physical memory size: 128B → physical address size: 7-bit ($2^7 = 128B$)
- ✓ Virtual address: consists of **VPN** (virtual page number) and **offset**
 - Page (and frame) size: 16B → offset size: 4-bit. As the result, the remaining 2-bit becomes VPN (note that there are 4 pages (2^2))
 - **VPN is used for searching page table**: VPN → **PFN** (Physical Frame Number)
- ✓ Physical address
 - PFN x page size + offset (VPN is translated while offset is not)
- ✓ Example
 - Virtual address: 21 → bit: 01 0101 → VPN: 01, offset: 0101 → PFN: 111 → $111 * 16B + 0101$ → physical address: 117

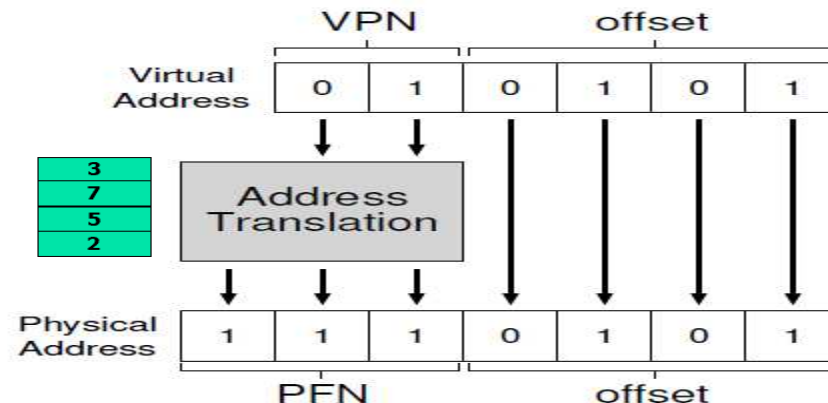
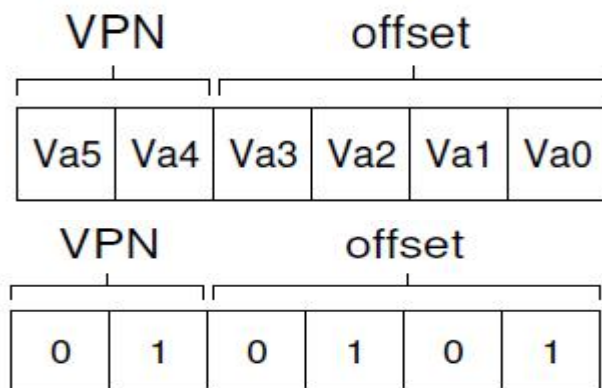

Figure 18.3: The Address Translation Process

18.2 Where Are Page Table Stored?

■ Address translation summary

- ✓ 1. **Virtual address** is divided in two parts: page number(p) and offset(d)
 - Page number: used as an **index** into a page table
 - Offset: used to locate the physical address within a frame
- ✓ 2. Each entry of the PT contains the starting address of the frame.
- ✓ 3. Combining the starting address with the offset → **physical address**

■ How to manage page table?

- ✓ Per process data structure
- ✓ Stored in PCB (or separated data structure linked with PCB) in kernel space → **in memory**

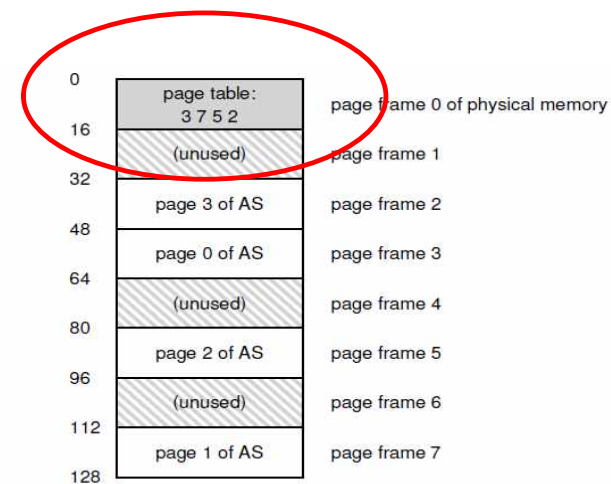
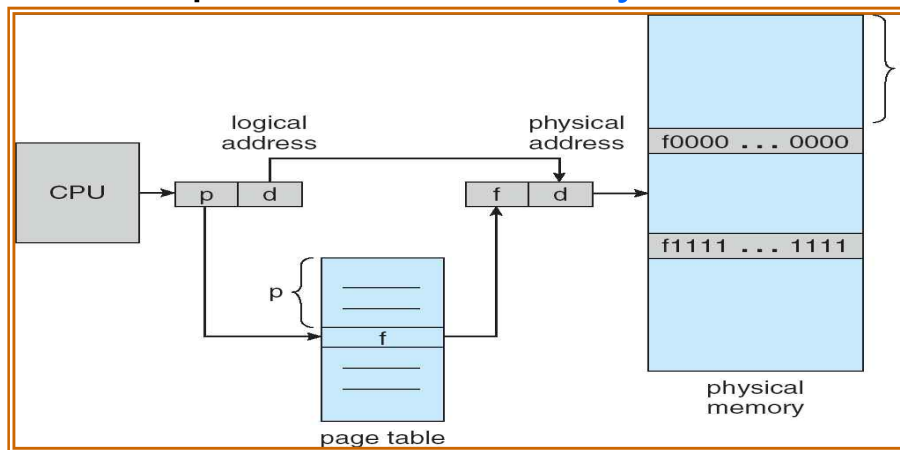

Figure 18.4: Example: Page Table in Kernel Physical Memory

(Source: A. Silberschatz, "Operating System Concept")

18.2 Where Are Page Table Stored?

■ Why in memory? (instead of CPU)

- ✓ Note that the base/limit register is in CPU.
- ✓ Since the page table is too large.
 - 32-bit CPU, page: 4KB → offset: 12-bit, VPN: 20-bit
 - 2^{20} entries in a page table → PTE (Page Table Entry)
 - Usually 4B per PTE → $2^{20} \times 4B = 4MB$ size
- ✓ Assume that there are 100 processes
 - $100 \times 4MB = 400MB$ for page tables
 - Too big to fit in a CPU → place them in memory

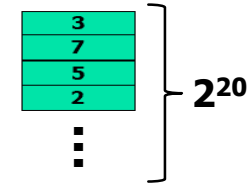

■ Two Issues

- ✓ Each memory access requires address translation → translation needs to access a page table → page table is in memory → Does this mean that each memory access actually requires two memory accesses? → TLB (Translation Lookaside Buffer) → chapter 19
- ✓ Even though they are in memory, they are still big → fixed size chopping requires a large amount of mapping information → multi-level page table or inverted page table → chapter 20

18.3 What's actually in the Page Table?

■ Page table

- ✓ Consists of PTEs(Page Table Entries), where each maps a page into a page frame (map a virtual address into a physical address)
 - like an array where each entry is indexed by VPN, having PFN as the value of each entry
- ✓ In addition, each PTE has several information bits
 - P (Present bit): whether this page is in physical memory or on disk (swap out)
 - R/W (Read/Write bit): Whether writes are allowed to this page
 - U/S (User/Supervisor bit): if user-mode processes can access the page
 - A (Access bit, a.k.a. reference bit): for replacement
 - D (Dirty bit): whether the page has been modified
 - Others
 - G, PAT, PCD, PWT: determine how HW caching works for the page
 - Valid bit: used or unused (e.g. space between stack and heap which is not used)
 - Various Protection bits

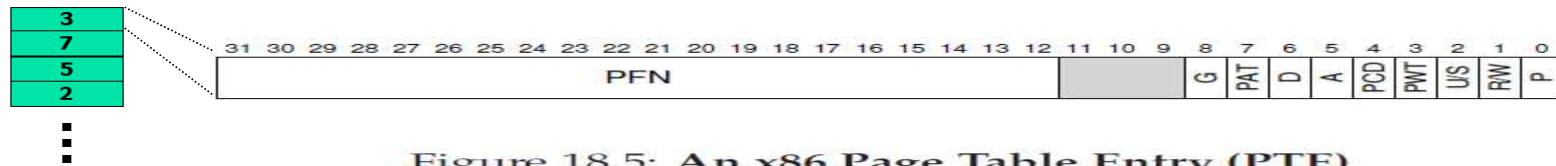
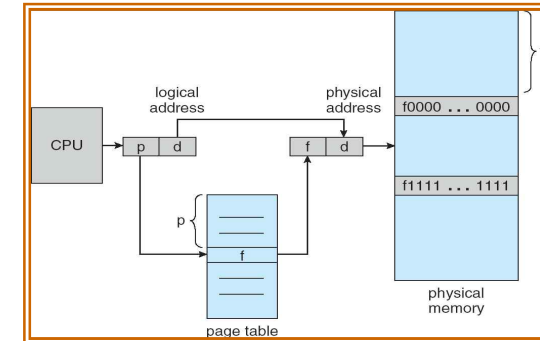

Figure 18.5: An x86 Page Table Entry (PTE)

👉 **What is the difference between page fault (P bit) and segmentation fault (Valid bit)?**

18.4 Paging: Also Too Slow

- To access memory (e.g. `mov 21, %eax`)
 - ✓ Find PTE address
 - PTBR: Page table base register
 - ✓ Fetch PTE /* access memory */
 - ✓ Check bits
 - ✓ Fetch physical address /* access memory again */



```
1 // Extract the VPN from the virtual address
2 VPN = (VirtualAddress & VPN_MASK) >> SHIFT
3
4 // Form the address of the page-table entry (PTE)
5 PTEAddr = PTBR + (VPN * sizeof(PTE))
6
7 // Fetch the PTE
8 PTE = AccessMemory(PTEAddr)
9
10 // Check if process can access the page
11 if (PTE.Valid == False)
12     RaiseException(SEGMENTATION_FAULT)
13 else if (CanAccess(PTE.ProtectBits) == False)
14     RaiseException(PROTECTION_FAULT)
15 else
16     // Access is OK: form physical address and fetch it
17     offset = VirtualAddress & OFFSET_MASK
18     PhysAddr = (PTE.PFN << PFN_SHIFT) | offset
19     Register = AccessMemory(PhysAddr)
```

Figure 18.6: Accessing Memory With Paging

18.5 A Memory Trace

- High-level viewpoint

```
int array[1000];  
...  
for (i = 0; i < 1000; i++)  
    array[i] = 0;
```

- Assembly viewpoint

```
1024 movl $0x0, (%edi,%eax,4)  
1028 incl %eax  
1032 cmpl $0x03e8,%eax  
1036 jne 0x1024
```

- Memory trace

 - Assumption

 - Page/frame size: 1KB (1024B)
 - Code: VPN:1, PFN:4 (PA = 4*1024)
 - Array: VPN:39, PFN:7 (PA = 7*1024)
 - PT: located in PA 1024

 - Figure 18.7: first five loop

 - PT[1] for instruction address
 - Instruction fetch
 - PT[39] for data address
 - Data fetch
 - 10 memory accesses per each loop (4 for instruction, 1 for data, 5 for PT)

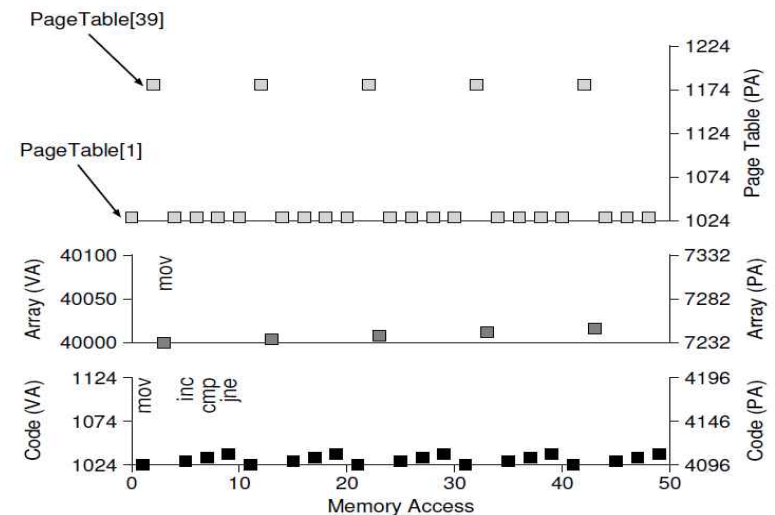

Figure 18.7: A Virtual (And Physical) Memory Trace



Quiz for 13th-Week 2nd-Lesson

■ Quiz

- ✓ 1. Discuss the differences among 1) contiguous allocation, 2) segmentation and 3) paging.
- ✓ 2. Assume that
 - Size of virtual memory = 64B, Size of physical memory = 128B, and Size of page and page frame = 16B (same as 7 page)
 - Frame 3, 6, 1 are used for page 0, 1, 2 (different compared to 7 page)
 - What are the physical addresses for virtual addresses of 4, 21 and 60? Explain the answers using the VPN, PFN and offset.
- ✓ Due: until 6 PM Friday of this week (28th, May)

3
6
1
Not P

Page table for this quiz

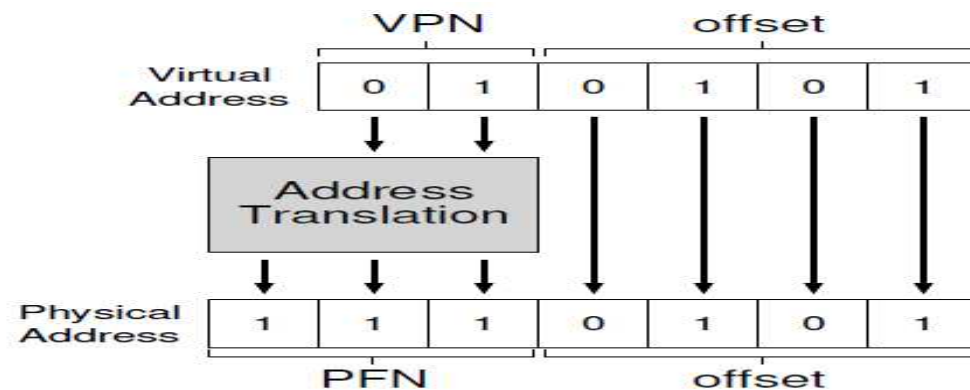
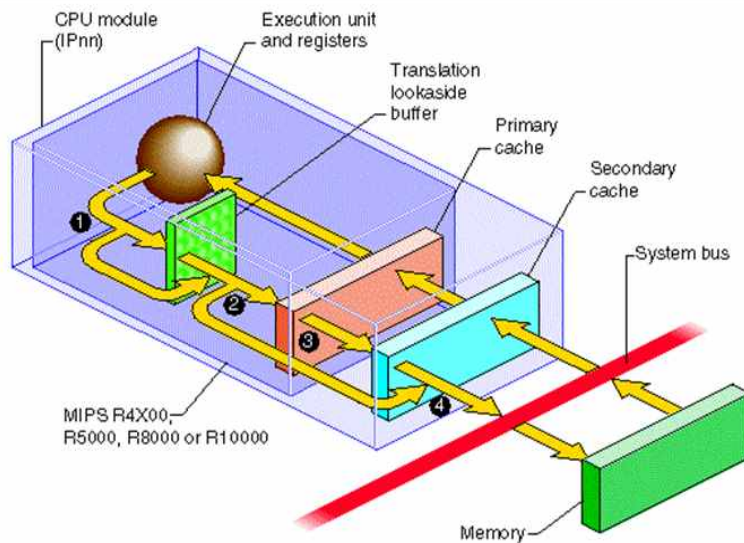

Figure 18.3: The Address Translation Process

Chap. 19 Paging: Faster Translations (TLBs)

■ TLB (Translation Lookaside Buffer)

- ✓ A part of MMU (Memory Management Unit) for faster translation
- ✓ Cache of recent used PTEs (popular virtual-to-physical pairs) → a better name would be **an address-translation cache**
- ✓ Translation step: 1) HW first check TLB, 2) if (hit), translation performs quickly without having to consult PT, 3) otherwise, access PT, 4) update TLB to cache the recently used PTE



(Source: Google Image)

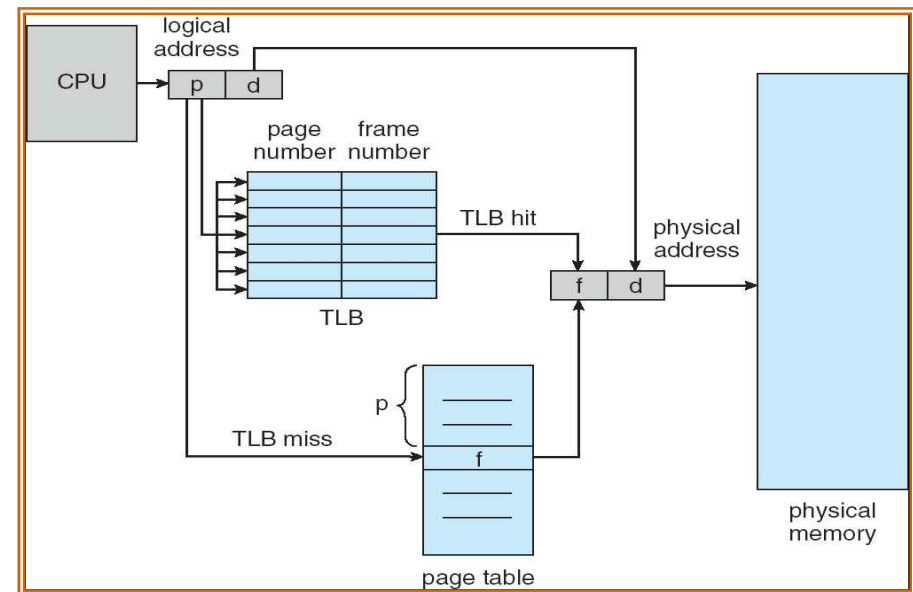

(Source: A. Silberschatz, "Operating system Concept")

19.1 TLB Basic Algorithm

- How HW might handle an address translation?
 - ✓ Hit → only one memory access (line 7)
 - ✓ Miss → two accesses, one for PTE (line 12) and the other for read data access (line 7 via line 19) + TLB update (line 18)
 - ✓ Locality: most accesses hit in TLB

```
1  VPN = (VirtualAddress & VPN_MASK) >> SHIFT
2  (Success, TlbEntry) = TLB_Lookup(VPN)
3  if (Success == True) // TLB Hit
4      if (CanAccess(TlbEntry.ProtectBits) == True)
5          Offset = VirtualAddress & OFFSET_MASK
6          PhysAddr = (TlbEntry.PFN << SHIFT) | Offset
7          Register = AccessMemory(PhysAddr)
8      else
9          RaiseException(PROTECTION_FAULT)
10 else // TLB Miss
11     PTEAddr = PTBR + (VPN * sizeof(PTE))
12     PTE = AccessMemory(PTEAddr)
13     if (PTE.Valid == False)
14         RaiseException(SEGMENTATION_FAULT)
15     else if (CanAccess(PTE.ProtectBits) == False)
16         RaiseException(PROTECTION_FAULT)
17     else
18         TLB_Insert(VPN, PTE.PFN, PTE.ProtectBits)
19         RetryInstruction()
```

Figure 19.1: TLB Control Flow Algorithm

19.2 Example: Accessing an Array

■ Example code

- ✓ `int a[10] → 4B x 10`
- ✓ Page size: 16B → 4 array entries at most → Assume Figure 19.2 layout
- ✓ Memory access behavior
 - Access `a[0]` → TLB miss → two memory accesses
 - Access `a[1],a[2]` → TLB hit → one memory access
 - Access `a[3],a[7]` → TLB miss, Access `a[4/5/6], a[8/9]` → TLB hit
 - TLB hit ratio: 70% (usually > 99% in general)

```
int sum = 0;
for (i = 0; i < 10; i++) {
    sum += a[i];
}
```

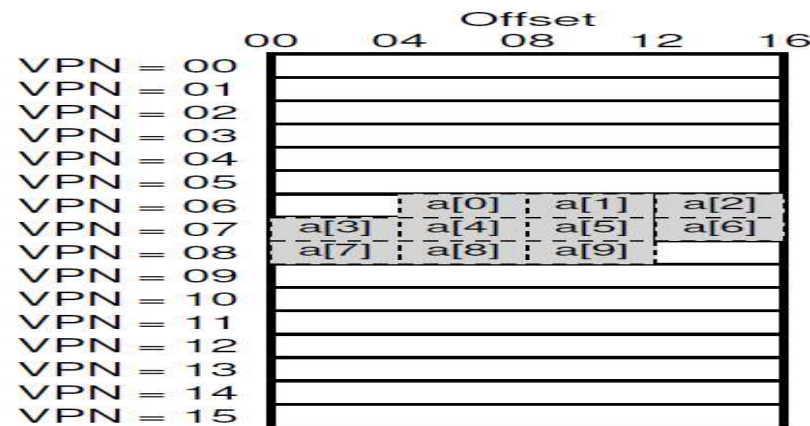

Figure 19.2: Example: An Array In A Tiny Address Space

- 👉 If the page size is 32B, how is TLB miss ratio?
- 👉 What about if there exists an outer loop? (e.g. “for (j=0; j<2; j++)”)

19.2 Example: Accessing An Array

- Use caching when possible

TIP: USE CACHING WHEN POSSIBLE

Caching is one of the most fundamental performance techniques in computer systems, one that is used again and again to make the “common-case fast” [HP06]. The idea behind hardware caches is to take advantage of locality in instruction and data references. There are usually two types of locality: temporal locality and spatial locality. With temporal locality, the idea is that an instruction or data item that has been recently accessed will likely be re-accessed soon in the future. Think of loop variables or instructions in a loop; they are accessed repeatedly over time. With spatial locality, the idea is that if a program accesses memory at address x , it will likely soon access memory near x . Imagine here streaming through an array of some kind, accessing one element and then the next. Of course, these properties depend on the exact nature of the program, and thus are not hard-and-fast laws but more like rules of thumb.

Hardware caches, whether for instructions, data, or address translations (as in our TLB) take advantage of locality by keeping copies of memory in small, fast on-chip memory. Instead of having to go to a (slow) memory to satisfy a request, the processor can first check if a nearby copy exists in a cache; if it does, the processor can access it quickly (i.e., in a few CPU cycles) and avoid spending the costly time it takes to access memory (many nanoseconds).

You might be wondering: if caches (like the TLB) are so great, why don't we just make bigger caches and keep all of our data in them? Unfortunately, this is where we run into more fundamental laws like those of physics. If you want a fast cache, it has to be small, as issues like the speed-of-light and other physical constraints become relevant. Any large cache by definition is slow, and thus defeats the purpose. Thus, we are stuck with small, fast caches; the question that remains is how to best use them to improve performance.

19.3 Who Handles the TLB Miss?

■ Two approaches

✓ HW-managed TLB

- HW has a logic to manipulate TLB including TLB update
- HW must exactly know the PT format, address format, ...
- E.g.) Intel CPU → CISC

✓ SW-managed TLB

- HW simply raises an exception
- OS (TLB trap handler) explicitly manages TLB → more flexible
- E.g.) MIPS, Sun SPARC v9 → RISC

```
1  VPN = (VirtualAddress & VPN_MASK) >> SHIFT
2  (Success, TlbEntry) = TLB_Lookup(VPN)
3  if (Success == True)    // TLB Hit
4      if (CanAccess(TlbEntry.ProtectBits) == True)
5          Offset    = VirtualAddress & OFFSET_MASK
6          PhysAddr  = (TlbEntry.PFN << SHIFT) | Offset
7          Register  = AccessMemory(PhysAddr)
8      else
9          RaiseException(PROTECTION_FAULT)
10 else    // TLB Miss
11     RaiseException(TLB_MISS)
```

Figure 19.3: TLB Control Flow Algorithm (OS Handled)

19.4 TLB Contents: What's in There?

■ A TLB entry

- ✓ VPN + PFN + bits (32 or 64 or 128 bits)

VPN | PFN | other bits

- ✓ Bits

- Valid bit: whether the entry has a valid translation or not
- Protection bits: R/W/E
- Others: ASID (Address-Space Identifier), dirty bit, ...

- ✓ Fully-associative

- Can place any entry

- ✓ Search in parallel

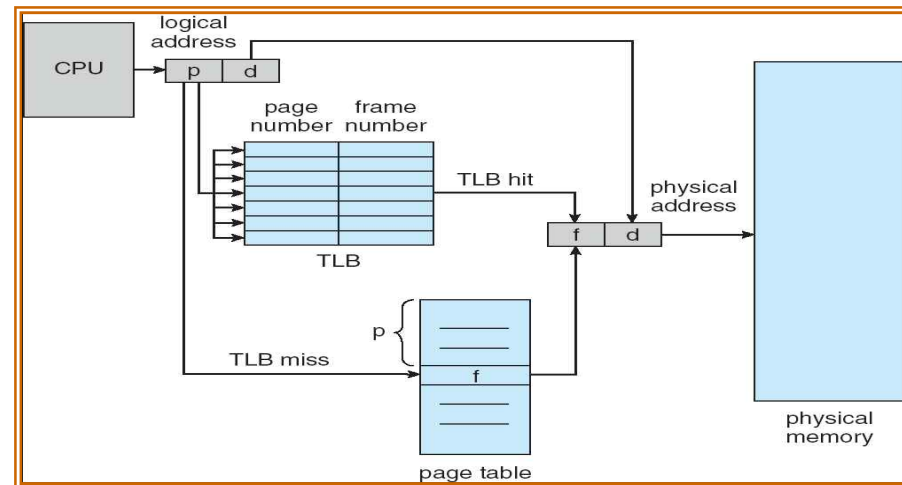

(Source: A. Silberschatz, "Operating system Concept")

19.5 TLB Issue: Context Switches

■ TLB

- ✓ Contains virtual-to-physical mapping
- ✓ Only valid for current-running process
 - Context Switch → need to invalid or distinguish TLB entries btw processes
- ✓ Example
 - P1: VPN 10 → PFN 100, P2: VPN 10 → PFN 170
 - P1 run → P1 accesses VPN 10 → CS from P1 to P2 → P2 accesses VPN 10 → Case 1: **cause problem**
 - Solution: 1) flush before CS (set all valid bit as 0) → **case 2**, 2) ASID (Address Space Identifier) → **case 3**
 - TLB flush is a heavy operation → causing high TLB misses

VPN	PFN	valid	prot
10	100	1	rwX
—	—	0	—
10	170	1	rwX
—	—	0	—

Case 1)

VPN	PFN	valid	prot
10	100	0	rwX
—	—	0	—
10	170	1	rwX
—	—	0	—

Case 2)

VPN	PFN	valid	prot	ASID
10	100	1	rwX	1
—	—	0	—	—
10	170	1	rwX	2
—	—	0	—	—

Case 3)

Chap. 20 Paging: Smaller Tables

■ Page table

- ✓ Locate in main memory
 - 1) Increase the number of memory accesses → TLB (chapter 19)
 - 2) Space overhead → this chapter
- ✓ How large it is?
 - 32-bit address space (2^{32}), 4KB page size (2^{12}) → PTEs in PT = 2^{20}
 - PTE size = 4B → 4MB for a PT (read page 1 of chapter 20 in OSTEP)
 - Note that PT is managed per a process (400MB if there are 100 processes) → May cause a memory shortage
- ✓ How to make smaller PT?
 - Bigger pages (page size: 4KB → 2MB, called huge page)
 - Hybrid approach: segmentation + paging
 - [Multi-level page table](#)
 - Inverted page table

20.1 Simple Solution: Bigger Pages

■ Bigger pages

- ✓ 32-bit address space (2^{32}), 4B for PTE
 - 4KB Page size (2^{12}) → PTEs in PT = 2^{20} → PT size = 4MB
 - 8KB Page size (2^{13}) → PTEs in PT = 2^{19} → PT size = 2MB
 - 4MB Page size (2^{22}) → PTEs in PT = 2^{10} → PT size = 4KB
- ✓ Pros): Simple, positive effect on TLB hit
- ✓ Cons): Internal fragmentation (waste of memory), heavy loading time
- ✓ How about multiple sizes for page?
 - Support 4KB, 16KB and 4MB at the same time (like huge page + base page in Intel)
 - Pros): Flexible, less internal fragmentation
 - Cons): Complexity in OS (still in progress)



20.3 Multi-level Page Table

■ Idea

- ✓ Using structural PTs (instead of **linear table**) → **multi-level table**
 - **Page directory**: each entry represents related PT
 - Can reduce a large number of unallocated page tables using valid bits in the page directory

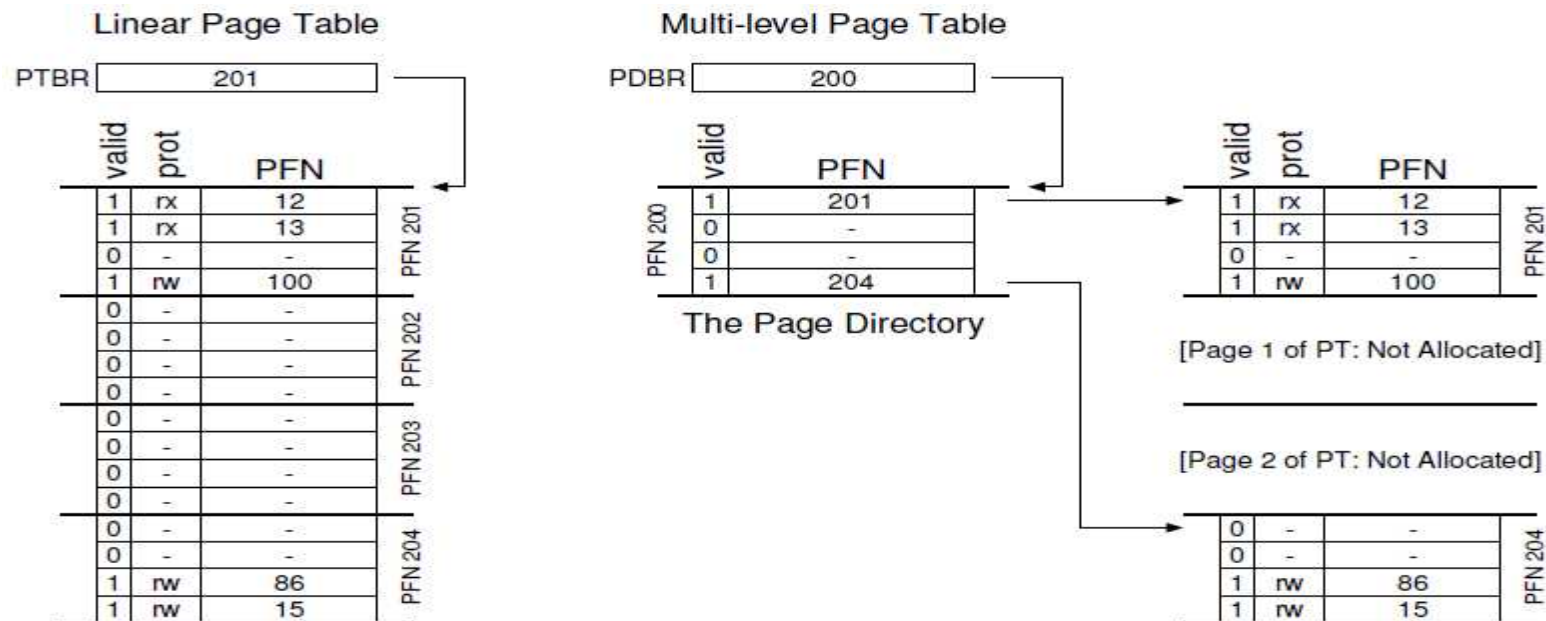
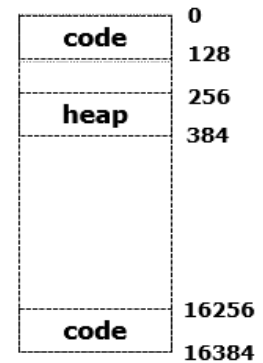
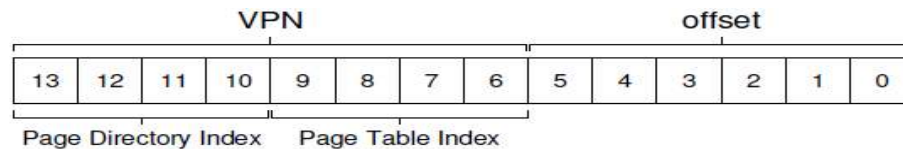

Figure 20.3: Linear (Left) And Multi-Level (Right) Page Tables

20.3 Multi-level Page Table

Address translation

- ✓ Virtual address is divided into three parts: Directory index, PT index and offset (instead of two parts: VPN, offset)
 - Virtual memory size: 16KB → address : 14bit
 - Page size: 64B → offset bit: 6bit
 - PTEs in a frame: 16 → PT index: 4bit
 - PTEs in a directory: 16 → Directory index: 4bit



Page Directory		Page of PT (@PFN:100)			Page of PT (@PFN:101)		
PFN	valid?	PFN	valid	prot	PFN	valid	prot
100	1	10	1	r-x	—	0	—
—	0	23	1	r-x	—	0	—
—	0	—	0	—	—	0	—
—	0	—	0	—	—	0	—
—	0	80	1	rw-	—	0	—
—	0	59	1	rw-	—	0	—
—	0	—	0	—	—	0	—
—	0	—	0	—	—	0	—
—	0	—	0	—	—	0	—
—	0	—	0	—	—	0	—
—	0	—	0	—	—	0	—
—	0	—	0	—	—	0	—
—	0	—	0	—	—	0	—
—	0	—	0	—	—	0	—
—	0	—	0	—	55	1	rw-
101	1	—	0	—	45	1	rw-

Figure 20.5: A Page Directory, And Pieces Of Page Table

- E.g. 1) VA = 100 → 00 0000 0110 0100 → Directory: 0000, PT index: 0001, Offset: 100100 → PA = 23 * 64B + 32 + 4
- E.g. 2) VA= 300 → 00 0001 0010 1100 → Directory: 0000, PT index: 0100, offset: 101100 → PA = 80* 64B + 32+8+4
- E.g. 3) 16257 = 11 1111 1000 0001 → Directory: 1111, PT index: 1110, offset: 000001 → PA = 55 x 64B + 1
- E.g. 4) VA= 200 → 00 0000 1100 1000 → Directory: 0000, PT index: 0011, offset: 001000 → **invalid in PT**
- E.g. 5) VA= 1030 → 00 0100 0000 0110 → Directory: 0001, PT index: 0000, offset: 000110 → **invalid in directory**

20.3 Multi-level Page Table

■ Address translation in Pseudo-code

- ✓ Concerns of the Multi-level PT
 - Address translation requires two accesses to PTs (vs. one access in the linear approach)
 - Increased HW complexity for multi-level translation
- ✓ Remember TLB → It can hide them

```
1  VPN = (VirtualAddress & VPN_MASK) >> SHIFT
2  (Success, TlbEntry) = TLB_Lookup(VPN)
3  if (Success == True) // TLB Hit
4      if (CanAccess(TlbEntry.ProtectBits) == True)
5          Offset = VirtualAddress & OFFSET_MASK
6          PhysAddr = (TlbEntry.PFN << SHIFT) | Offset
7          Register = AccessMemory (PhysAddr)
8      else
9          RaiseException (PROTECTION_FAULT)
10 else // TLB Miss
11     // first, get page directory entry
12     PDIndex = (VPN & PD_MASK) >> PD_SHIFT
13     PDEAddr = PDBR + (PDIndex * sizeof(PDE))
14     PDE = AccessMemory (PDEAddr)
15     if (PDE.Valid == False)
16         RaiseException (SEGMENTATION_FAULT)
17     else
18         // PDE is valid: now fetch PTE from page table
19         PTIndex = (VPN & PT_MASK) >> PT_SHIFT
20         PTEAddr = (PDE.PFN << SHIFT) + (PTIndex * sizeof(PTE))
21         PTE = AccessMemory (PTEAddr)
22         if (PTE.Valid == False)
23             RaiseException (SEGMENTATION_FAULT)
24         else if (CanAccess(PTE.ProtectBits) == False)
25             RaiseException (PROTECTION_FAULT)
26         else
27             TLB_Insert (VPN, PTE.PFN, PTE.ProtectBits)
28             RetryInstruction ()
```

Figure 20.6: Multi-level Page Table Control Flow

20.3 Multi-level Page Table

- More than two levels

- Virtual address: 30-bit, page size: 512B

- Address: 30bit, offset: 9bit → VPN: 21bit, PTEs in a page: 128 (512/4)

- 2-level: left figure

- PT index = 7 bit ($2^7 = 128$), Page directory: need to cover remaining 14-bits → 2^{14} PTEs → 128 pages for Page directory

- 3-level: right figure

- PT index = 7 bit, PD index0 = 7 bit (upper-level), PD index1 = 7 bit → one page for PD index0, PD index1 and PT needed only for valid PTEs → save memory

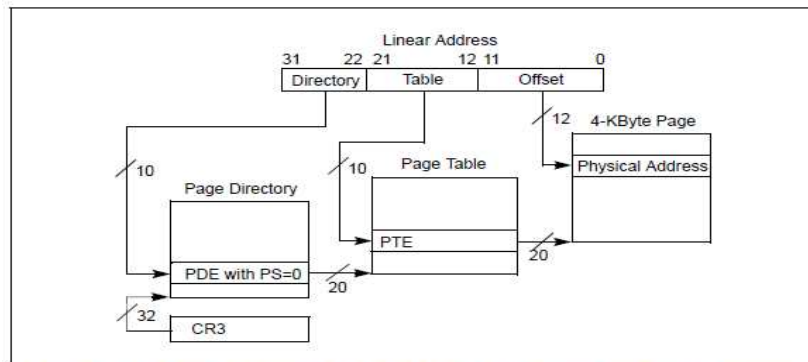
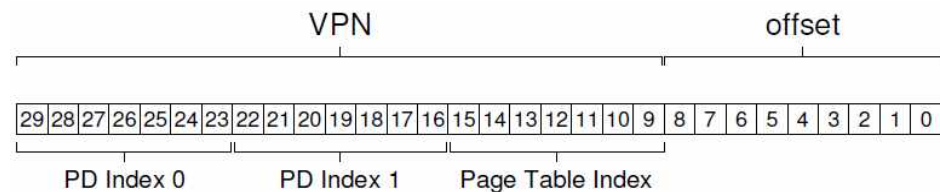
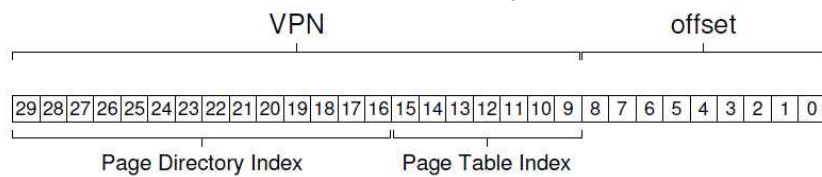

Figure 4-2. Linear-Address Translation to a 4-KByte Page using 32-Bit Paging

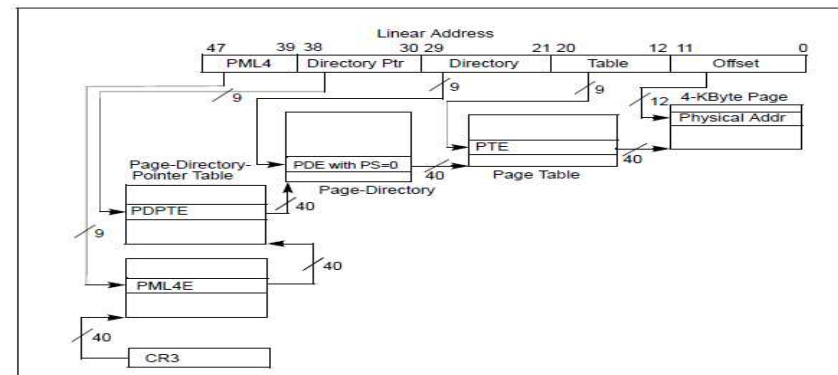

Figure 4-8. Linear-Address Translation to a 4-KByte Page using IA-32e Paging

(Source: Intel 64 and IA32 Architectures SW Developer's Manual, Volume 3: System Programming Guide, Chapter 4)

20.4 Inverted Page Tables

- Page table

- ✓ VPN → PFN, One per process in a system

- Inverted Page Table

- ✓ PFN → VPN, Only one in a system (hence reduce memory for PT)
 - Page table index: physical frame number (one entry per physical page)
 - PTE: virtual page number, process ID that maps the physical page
- ✓ Address Translation
 - Need search: 1) linear scan, 2) hash

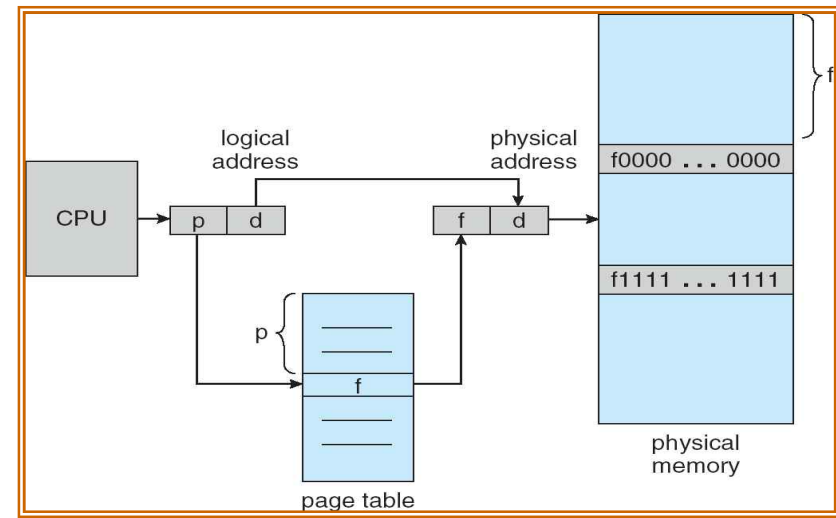
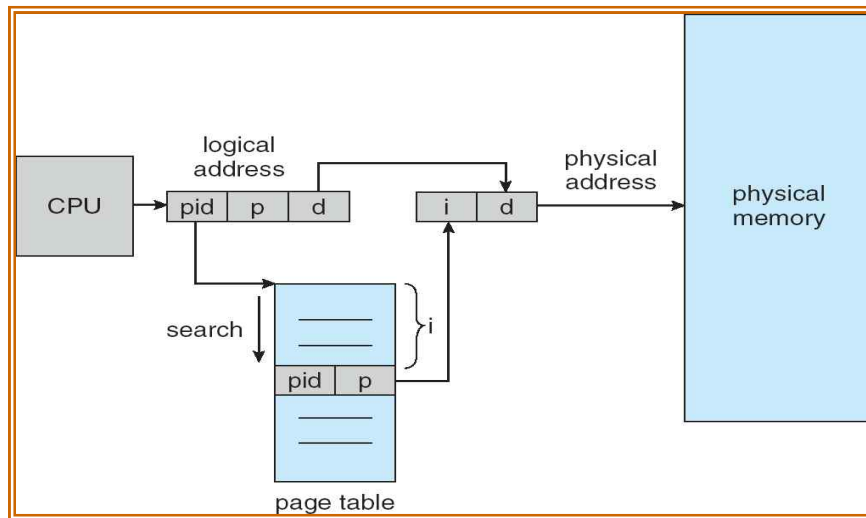

(Source: A. Silberschatz, "Operating system Concept")



Quiz for 14th-Week 1st-Lesson

■ Quiz

- ✓ 1. Explain the definition of 1) MMU, 2) TLB, 3) page directory and 4) inverted page table.
- ✓ 2. In page 18, we calculate that the TLB hit ratio for accessing a[] is 70%. 1) What is the TLB hit ratio when the page size is 32B (instead of 16B)? 2) What if there exists an outer loop like "for (j=0; j<2; j++)" above the "for (i=0; i<10; i++)"
- ✓ Due: until 6 PM Friday of this week (4th, June)

```
int sum = 0;
for (i=0; i<10; i++) {
    sum += a[i];
}
```

```
int sum = 0;
for (j=0; j<2; j++)
    for (i=0; i<10; i++) {
        sum += a[i];
    }
```

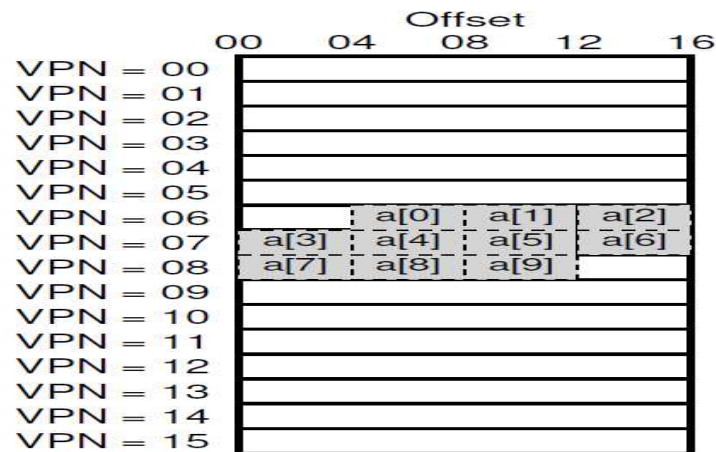
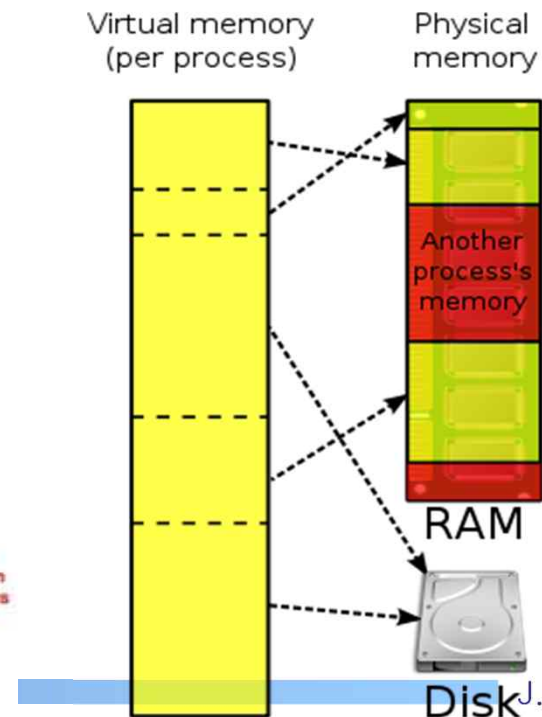
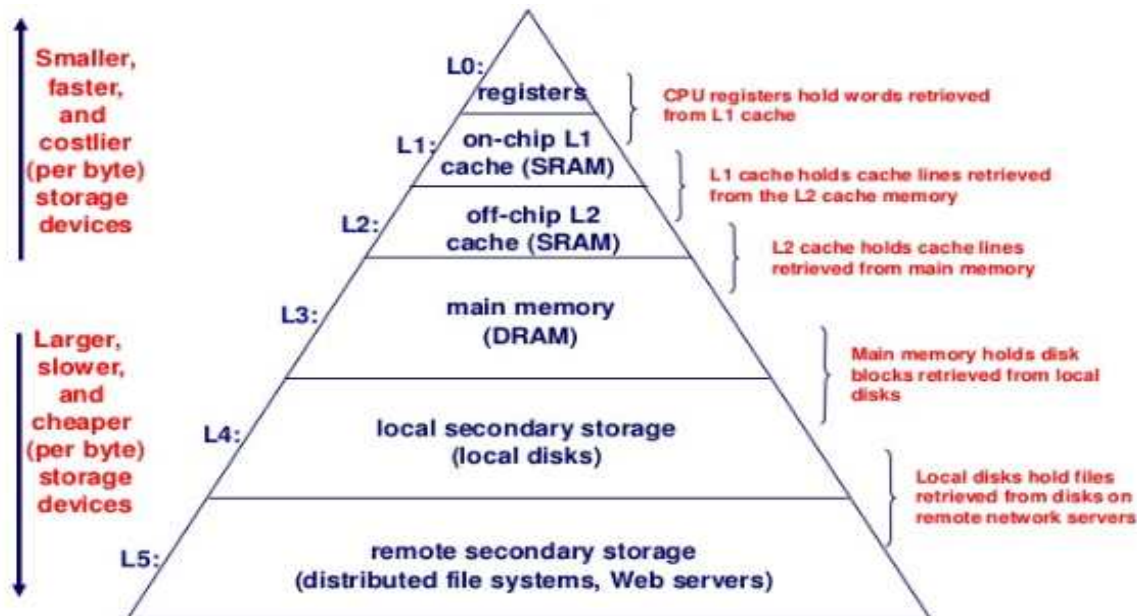

Figure 19.2: Example: An Array In A Tiny Address Space

Chap. 21 Beyond Physical Memory: Mechanisms

■ Memory hierarchy

- ✓ Register, Cache, Memory, Disk (or SSD), Sever, ...
- ✓ VM (Virtual Memory) focus on Memory and Disk
 - Memory: relatively fast but small
 - Disk: relatively slow but large
- ✓ OS wants to execute multiple processes at the same time
 - Frequently accessed data → place in memory
 - Seldom accessed data → place in disk, bring into memory if necessary ([demand loading or demand paging](#))



21.1 Swap space

■ Swap definition

- ✓ Space in disk for moving pages back and forth
 - To migrate data from memory to disk when available memory space is insufficient
 - Moving granularity: page vs. process
 - When: light vs heavy memory hungry condition
 - How: replacement policy (LRU pages, low-priority processes)
 - E.g.) 4 frames and 8-page swap space
 - Proc 0/1/2 → ready or running, Proc 3 → suspended (swap out)

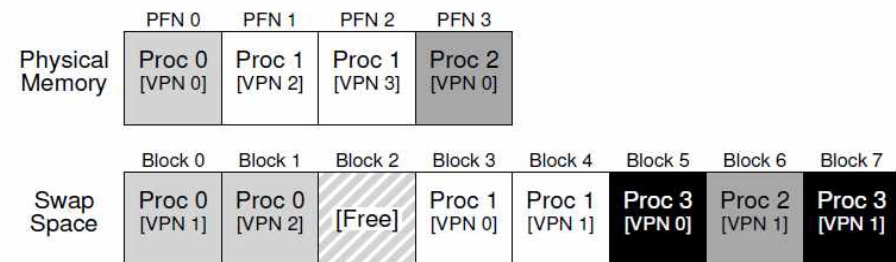
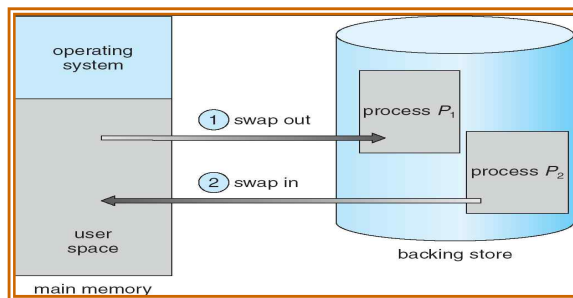

(Source: A. Silberschatz, "Operating system Concept")

Figure 21.1: Physical Memory and Swap Space

■ Benefit

- ✓ Allow to support the illusion of a large virtual memory for a process (usually larger than physical memory)
- ✓ Transparent to programmers (vs. memory overlay)

21.2 Present Bit / 21.3 Page Fault

■ Present bit in PTE

- ✓ To identify whether a page is in memory or swap out
 - Present bit == 1, access the page
 - Present bit == 0, → page fault

■ Page fault

- ✓ Trigger page fault handler that bring the page from disk to memory
- ✓ From swap space or from a file (e.g. demand loading)

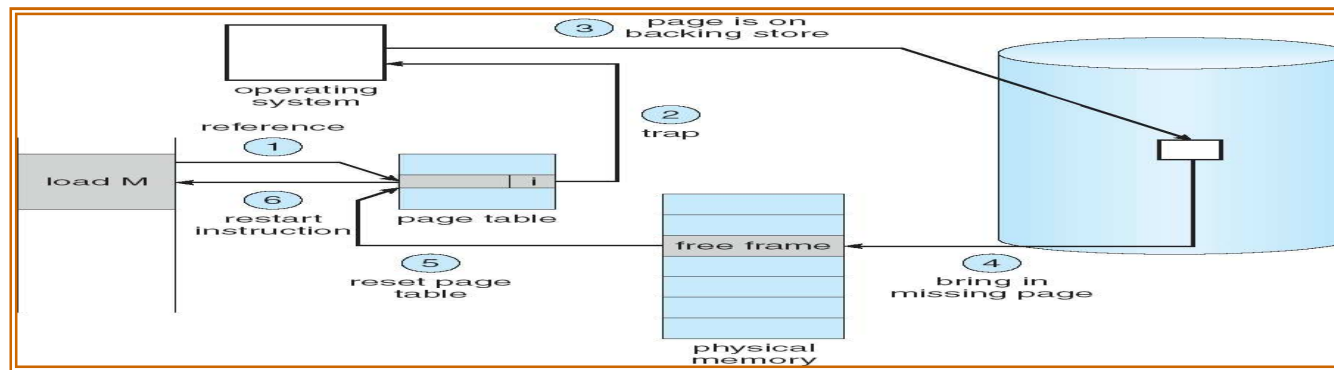

(Source: A. Silberschatz, "Operating system Concept")

- ☞ Features of paging: easy to support demand loading (fast execution), HW friendly, fixed, ..
- ☞ Load a page in virtual memory → Read a disk block in file system (using inode) → VM and FS works together in an integrated manner.

21.4 Page Fault Control Flow

■ HW control flow

```
1  VPN = (VirtualAddress & VPN_MASK) >> SHIFT
2  (Success, TlbEntry) = TLB_Lookup(VPN)
3  if (Success == True)    // TLB Hit
4      if (CanAccess(TlbEntry.ProtectBits) == True)
5          Offset = VirtualAddress & OFFSET_MASK
6          PhysAddr = (TlbEntry.PFN << SHIFT) | Offset
7          Register = AccessMemory(PhysAddr)
8      else
9          RaiseException(PROTECTION_FAULT)
10 else
11     // TLB Miss
12     PTEAddr = PTBR + (VPN * sizeof(PTE))
13     PTE = AccessMemory(PTEAddr)
14     if (PTE.Valid == False)
15         RaiseException(SEGMENTATION_FAULT)
16     else
17         if (CanAccess(PTE.ProtectBits) == False)
18             RaiseException(PROTECTION_FAULT)
19         else if (PTE.Present == True)
20             // assuming hardware-managed TLB
21             TLB_Insert(VPN, PTE.PFN, PTE.ProtectBits)
22             RetryInstruction()
23         else if (PTE.Present == False)
24             RaiseException(PAGE_FAULT)
```

Figure 21.2: Page-Fault Control Flow Algorithm (Hardware)

■ SW control flow

```
1  PFN = FindFreePhysicalPage()
2  if (PFN == -1) // no free page found
3      PFN = EvictPage() // run replacement algorithm
4      DiskRead(PTE.DiskAddr, pfn) // sleep (waiting for I/O)
5  PTE.present = True // update page table with present
6  PTE.PFN = PFN // bit and translation (PFN)
7  RetryInstruction() // retry instruction
```

Figure 21.3: Page-Fault Control Flow Algorithm (Software)

- ☞ What are the differences between the page fault and segmentation fault?
- ☞ What if there is no free frame? → Evict (see Chapter 22)

Chap. 22 Beyond Physical Memory: Policies

- **Demand paging** (a.k.a. demand loading)
 - ✓ Make mapping information without actual loading (fast execution)
 - ✓ Start running → occur page faults → loading in a lazy manner (we can load pages that are actually used)
 - ✓ Life is easy where there are a lot of free frames
- **When little memory is free**
 - ✓ Memory pressure forces OS for paging out to make room
 - ✓ **Replacement policy**: decide which page (or pages) to evict

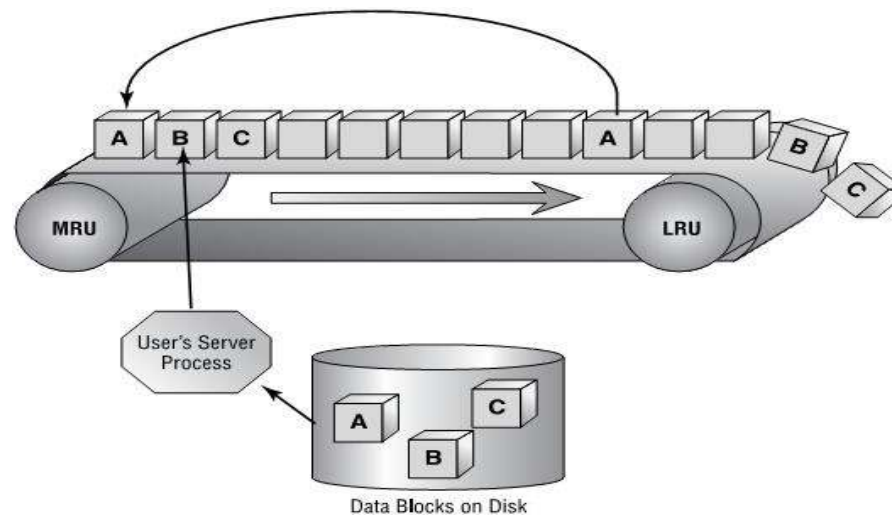

22.1 Cache Management

■ Goal

- ✓ Maximize **cache hit** (minimize cache miss)

■ Model

- ✓ Average memory access time (AMAT)

$$AMAT = (P_{Hit} \cdot T_M) + (P_{Miss} \cdot T_D)$$

■ Where

- T_M : memory access latency
- T_D : disk access latency
- P_{hit} : probability of finding data in the cache ($P_{miss} = 1 - P_{hit}$)

■ Example (Details can be found in the page 2 of chapter 22 in OSTEP)

- Assume that $T_M = 100\text{ns}$, $T_D = 10\text{ms}$ (10,000,000ns)
- $P_{hit} = 50\% \rightarrow AMAT = 0.5 \times 100 + 0.5 \times 10,000,000 = 5,000,050 = 5\text{ms}$
- $P_{hit} = 90\% \rightarrow AMAT = 0.9 \times 100 + 0.1 \times 10,000,000 = 1,000,090 = 1\text{ms}$
- $P_{hit} = 99\% \rightarrow AMAT = 0.99 \times 100 + 0.01 \times 10,000,000 = 100,099 = 0.1\text{ms}$

■ Hit ratio is quite important

- Expected hit ratio = S_M / S_D if an access pattern is the uniform distribution
- Remember locality which makes it feasible to obtain high hit ratio

22.2 Optimal Replacement Policy

- Optimal replacement policy (known as MIN)
 - ✓ Evict a page that will be accessed furthest in the future
 - Best replacement policy
 - Not implementable (comparison purpose, quite useful)
 - ✓ Example
 - Reference string: 0 1 2 0 1 3 0 3 1 2 1
 - Cache size: 3 frames
 - Hit ratio = $6/11 = 54.5\%$
 - Compulsory miss (Cold-start miss), Capacity miss, Conflict miss (Direct mapping or set-associative case)

Access	Hit/Miss?	Evict	Resulting Cache State
0	Miss		0
1	Miss		0, 1
2	Miss		0, 1, 2
0	Hit		0, 1, 2
1	Hit		0, 1, 2
3	Miss	2	0, 1, 3
0	Hit		0, 1, 3
3	Hit		0, 1, 3
1	Hit		0, 1, 3
2	Miss	3	0, 1, 2
1	Hit		0, 1, 2

Figure 22.1: Tracing The Optimal Policy

22.3 A Simple Policy: FIFO

- FIFO (First In First Out)

- ✓ Evict a page that was brought into memory for the first time
 - Like the FCFS scheduling policy (first-in page in a queue)
- ✓ Example with same reference string (0 1 2 0 1 3 0 3 1 2 1)
 - hit ratio = $4/11 = 36.4\%$

Access	Hit/Miss?	Evict	Resulting Cache State
0	Miss		First-in → 0
1	Miss		First-in → 0, 1
2	Miss		First-in → 0, 1, 2
0	Hit		First-in → 0, 1, 2
1	Hit		First-in → 0, 1, 2
3	Miss	0	First-in → 1, 2, 3
0	Miss	1	First-in → 2, 3, 0
3	Hit		First-in → 2, 3, 0
1	Miss	2	First-in → 3, 0, 1
2	Miss	3	First-in → 0, 1, 2
1	Hit		First-in → 0, 1, 2

Figure 22.2: Tracing The FIFO Policy

- ✓ Pros) Simple
- ✓ Cons) Not considering locality, Belady's anomaly (less hit ratio with larger cache)
 - Anomaly example: 1,2,3,4,1,2,5,1,2,3,4,5 with 3 and 4 frames

22.4 Another Simple Policy: Random

■ Random

- ✓ Evict a page chosen randomly
- ✓ Example: same reference string (0 1 2 0 1 3 0 3 1 2 1)
 - hit ratio = $5/11 = 45.4\%$ → Figure 22.3
 - Different at each trial → Figure 22.4
- ✓ Pros) Simple
- ✓ Cons) Not considering locality, unpredictable

Access	Hit/Miss?	Evict	Resulting Cache State
0	Miss		0
1	Miss		0, 1
2	Miss		0, 1, 2
0	Hit		0, 1, 2
1	Hit		0, 1, 2
3	Miss	0	1, 2, 3
0	Miss	1	2, 3, 0
3	Hit		2, 3, 0
1	Miss	3	2, 0, 1
2	Hit		2, 0, 1
1	Hit		2, 0, 1

Figure 22.3: Tracing The Random Policy

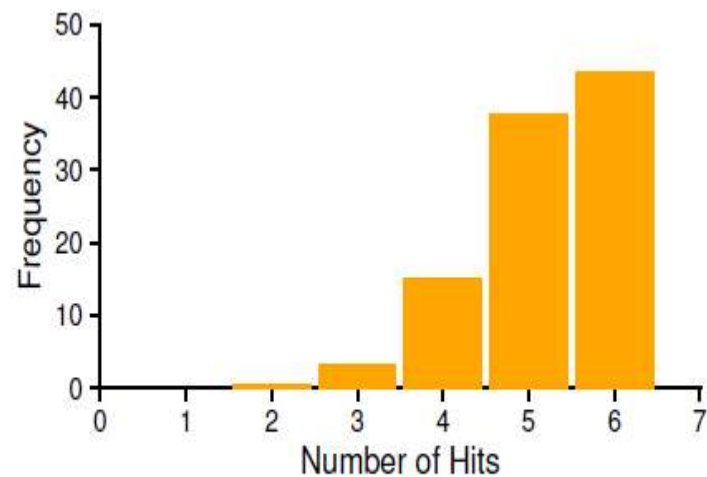

Figure 22.4: Random Performance Over 10,000 Trials

22.5 Using History: LRU

- LRU (Least Recently Used)

- ✓ Evict a page that was accessed oldest in the past
- ✓ Example: same reference string (0 1 2 0 1 3 0 3 1 2 1)
 - hit ratio = 6/11 = 54.5%
- ✓ Pros) Considering locality (temporal locality)
- ✓ Cons) Not good for the looping reference

Access	Hit/Miss?	Evict	Resulting Cache State
0	Miss		LRU → 0
1	Miss		LRU → 0, 1
2	Miss		LRU → 0, 1, 2
0	Hit		LRU → 1, 2, 0
1	Hit		LRU → 2, 0, 1
3	Miss	2	LRU → 0, 1, 3
0	Hit		LRU → 1, 3, 0
3	Hit		LRU → 1, 0, 3
1	Hit		LRU → 0, 3, 1
2	Miss	0	LRU → 3, 1, 2
1	Hit		LRU → 3, 2, 1

Figure 22.5: Tracing The LRU Policy

- ✓ History based policies
 - Use history as our guide (like [Multi-level feedback queue](#))
 - LRU, LFU (Least Frequently Used), LRFU, MRU, ARC, 2Q, ...

22.6 Workload Examples

■ Workload analysis

- ✓ Workload: amount of work, characteristics of references in this case
- ✓ 3 types in this slide
 - No-locality: LRU == FIFO == RAND
 - 80-20 workload (hot/cold): LRU > FIFO == RAND
 - Loop workload: LRU == FIFO < RAND
- ✓ Most applications show strong locality → LRU employed popularly
- ✓ Large cache size: close to optimal

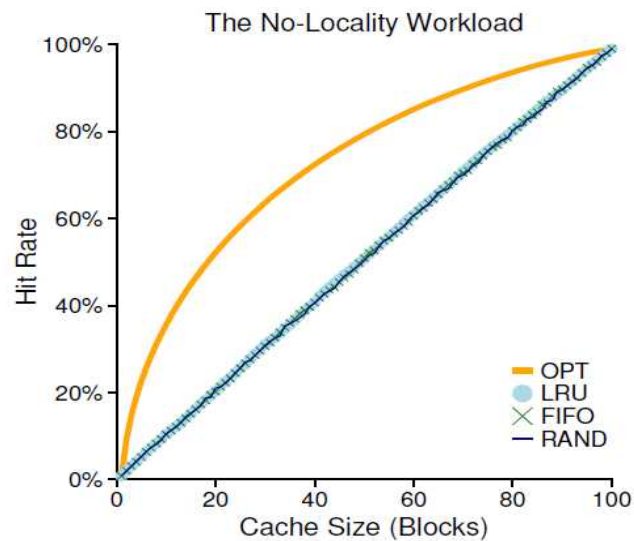

Figure 22.6: The No-Locality Workload

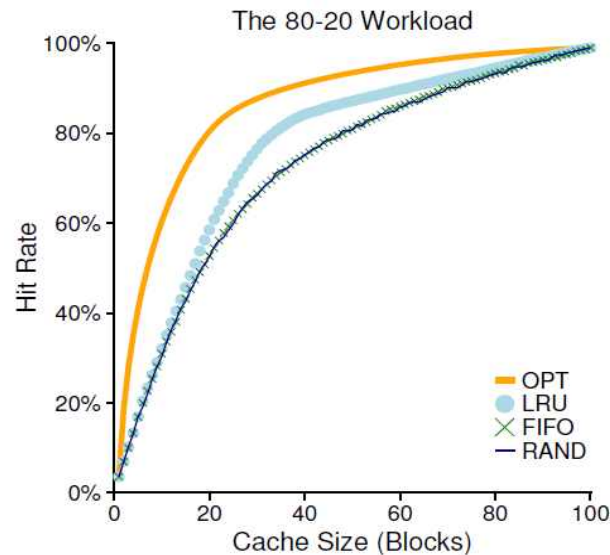

Figure 22.7: The 80-20 Workload

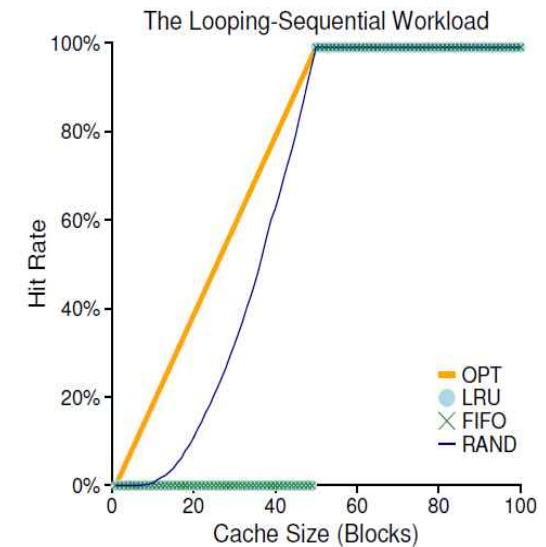
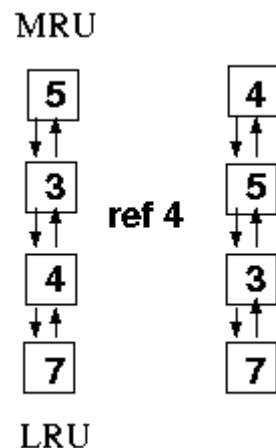

Figure 22.8: The Looping Workload

22.7 Implementing Historical Algorithms

■ How to implement LRU?

- ✓ Usually linked list
 - ✓ Pages access
 - Insert it to the head of the list (MRU position)
 - Move down all pages to the next position
 - Remove the page in the LRU position if necessary (miss case)
- ✓ Need to monitor all memory accesses
 - Feasible in the file cache or server cache
 - May degrade performance in the memory cache → utilize HW supports such as reference bit and dirty bit



Access	Hit/Miss?	Evict	Resulting Cache State
0	Miss		LRU → 0
1	Miss		LRU → 0, 1
2	Miss		LRU → 0, 1, 2
0	Hit		LRU → 1, 2, 0
1	Hit		LRU → 2, 0, 1
3	Miss	2	LRU → 0, 1, 3
0	Hit		LRU → 1, 3, 0
3	Hit		LRU → 1, 0, 3
1	Hit		LRU → 0, 3, 1
2	Miss	0	LRU → 3, 1, 2
1	Hit		LRU → 3, 2, 1

Figure 22.5: Tracing The LRU Policy

22.8 Approximating LRU

■ Clock algorithm

- ✓ FIFO with Reference bit (also called as Access bit, see 12 page)
 - HW: set reference bit as 1 when an associated page is accessed
 - OS: manage a pointer for next victim
 - if (ref_bit == 1), clear it to 0 and give **second chance** (check the next page)
 - if (ref_bit == 0), evict it and move the victim pointer to the next page
 - Approximate LRU well

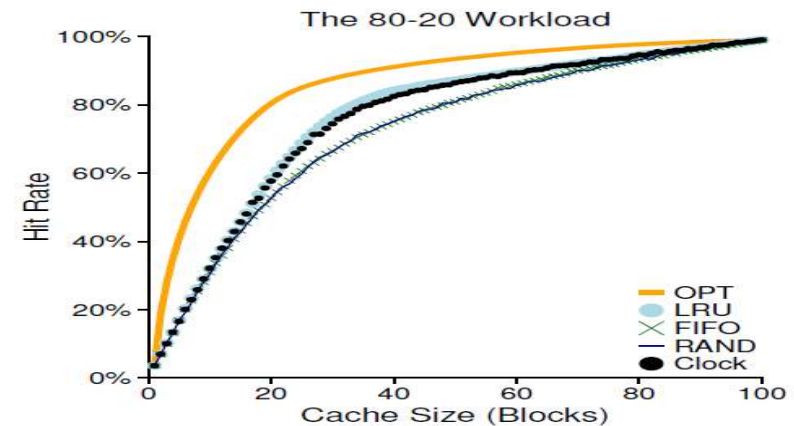
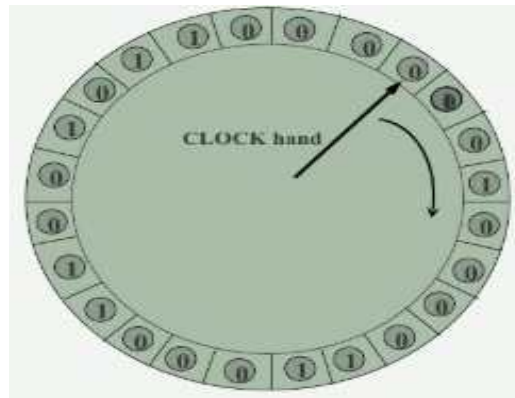

Figure 22.9: The 80-20 Workload With Clock

✓ Advanced version

- Periodic clearing
- Utilizing two HW bits: reference and dirty bit

22.11 Thrashing

■ Thrashing

- ✓ A situation where the page fault rate is extremely high as each process does not have enough frames
 - A page fault triggers to replace a page that will be referenced soon, which eventually making another page fault immediately
- ✓ A process is spending more time paging than executing

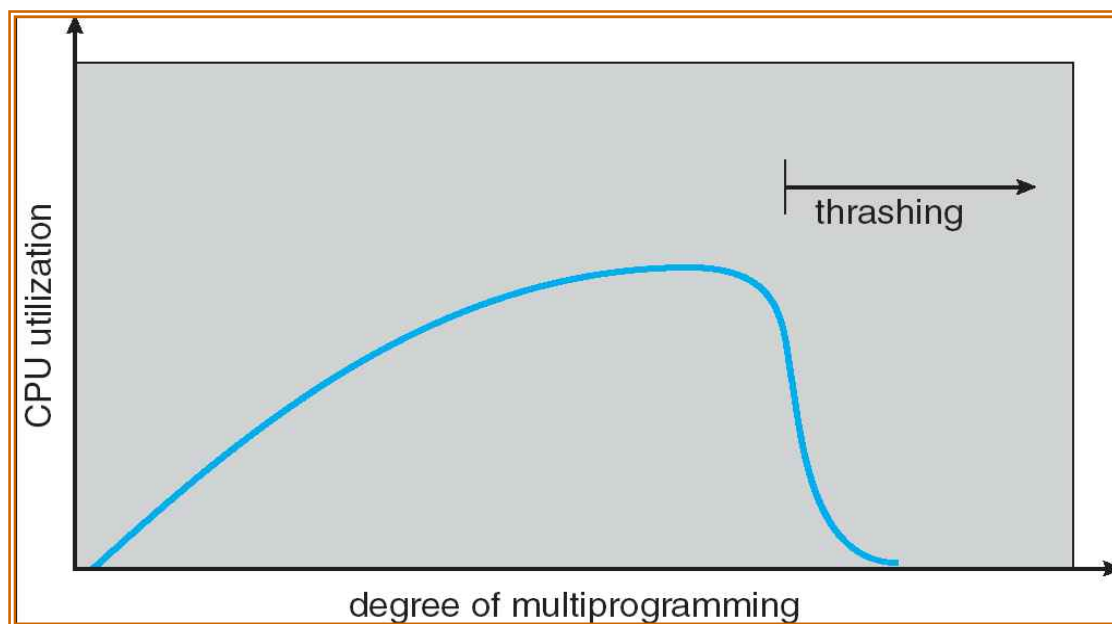

22.11 Thrashing

■ Working set

- ✓ **WS(t)**: a set of pages referenced between $t-\Delta$ and t
 - To estimate how much memory a process needs
- ✓ Application of working set
 - Detect thrashing or Find a chance for new process initiation
 - Mechanism: $D > m \Rightarrow$ Thrashing
 - WSS_i : Working Set Size of Process P_i
 - $D = \sum WSS_i$ (D : the total demand of frames for all process)
 - m : total # of available frames in a system
 - Working-set Strategy
 - If ($D > m$), suspend some of the processes
 - If ($D < m$), another process can be initiated
 - \rightarrow Prevent thrashing while keeping multiprogramming degree as high as possible.

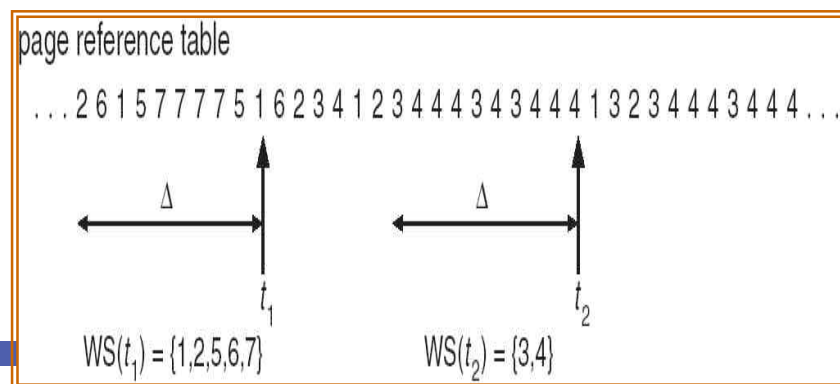

Summary

■ Virtual memory concept

- ✓ Separation of **virtual memory** from **physical memory**
 - Virtual memory: user's (or programmer's) viewpoint, exclusive
 - Physical memory: system's viewpoint, shared by multiple processes
- ✓ Allow the execution of a process **that are not completely in memory**
 - Logical address space can therefore be much larger than physical address space.
 - Allows more programs running

■ Virtual memory can be implemented via:

- ✓ 1) **Address translation: paging, segmentation, TLB**
- ✓ 2) **Demand paging: page fault, integration FS and VM**
- ✓ 3) **Replacement: LRU, FIFO, Clock, Working set, ...**

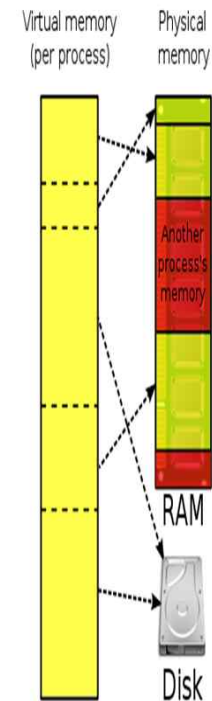



Quiz for 14th-Week 2nd-Lesson

■ Quiz

- ✓ 1. Discuss the terms of 1) demand paging, 2) page fault, 3) thrashing and 4) working set.
- ✓ 2. Calculate the hit ratio under the FIFO, LRU and Optimal (MIN) policies when there are three frames and the page reference string is "1, 2, 3, 4, 1, 2, 5, 1, 2, 3, 4, 5". What about when there are four frames?
- ✓ Bonus) Explain the Belady's anomaly using the Quiz 2.
- ✓ Due: until 6 PM Friday of this week (4th, June)

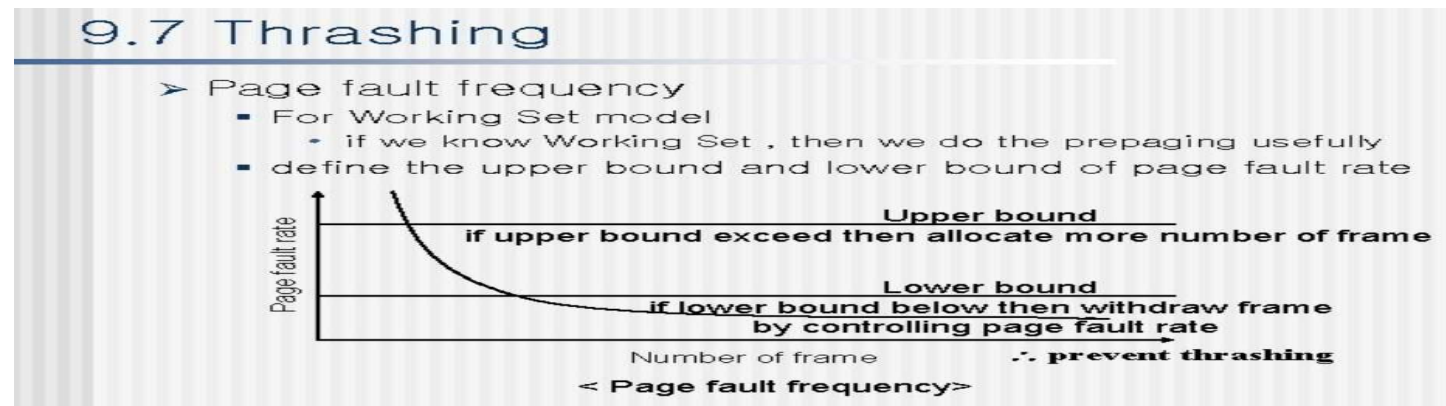

(Source: <https://slidetodoc.com/ch-10-operating-system-ch-10-v-m/>)

Appendix 1

Linux implementation for segmentation and paging

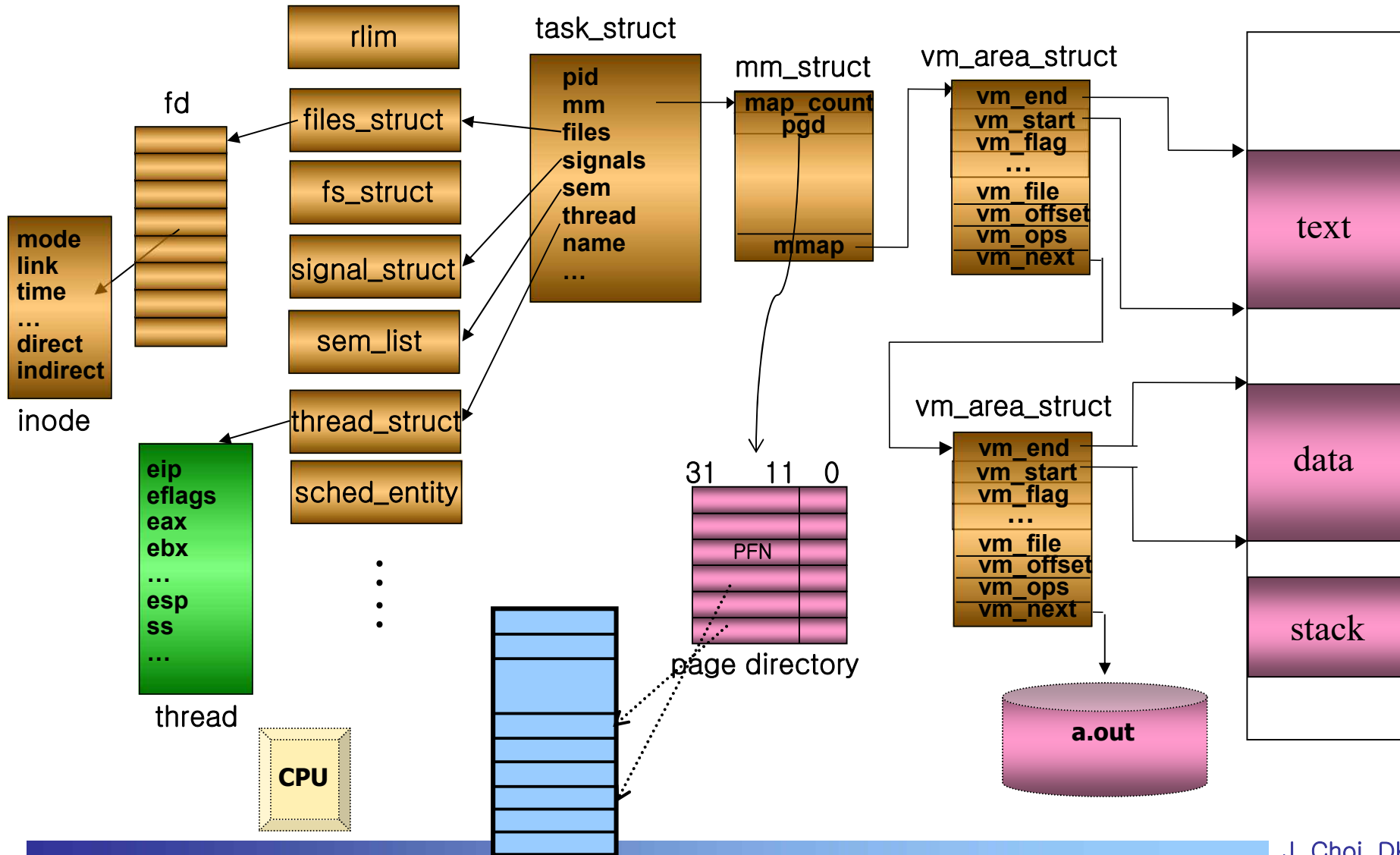

Appendix 1

■ Copy-on-Write (COW)

- ✓ Allow both processes can share pages even though they are not actually shared pages (set the copy-on-write bit in page table)
- ✓ If either process modifies a shared page, the page is copied
- ✓ Good for fork() and exec()
 - Allow both parent and child processes to initially *share* the same pages in memory
 - More efficient for process creation

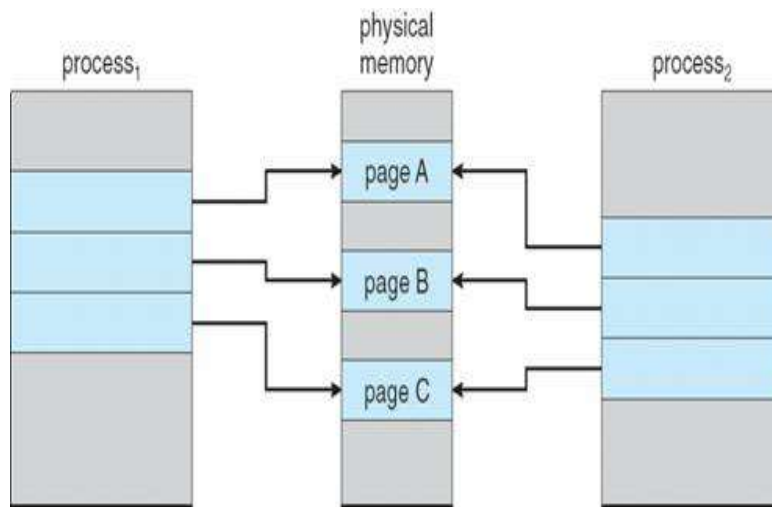

(Before process 1 modified page C)

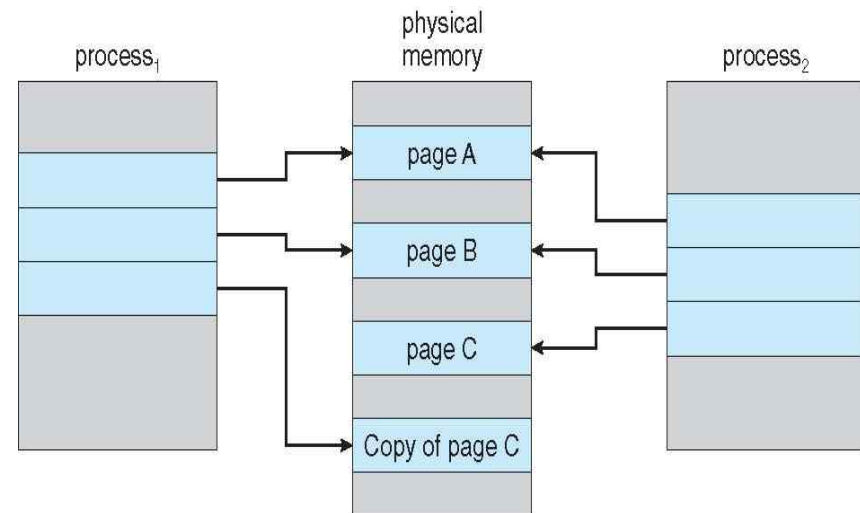

(After process 1 modified page C)

Appendix 2

■ 19.7 A Real TLB Entry

✓ Real TLB example: MIPS R4000

- SW-managed TLB, 4KB page/frame size
- 32 or 64 entries in TLB (related to TLB coverage)
- Bit description
 - VPN: 19-bits → we expect 20-bits. But, user addresses will only come from half of the address space (2GB for user, 2GB for kernel) → 19-bits are enough
 - PFN: 24-bits → support up to 64GB physical memory ($2^{24} \times 4\text{KB}$)
 - ASID: 8-bits, to identify which process own the VNP-PFN pair
 - G: global bit → shared among processes (ASID is ignored)
 - C: coherence bit → for coherence protocol
 - D: dirty bit
 - V: valid bit
 - Page mask: for supporting multiple page sizes



Figure 19.4: A MIPS TLB Entry

Appendix 2

■ 21.6 When Replacements Really Occur

- ✓ OS actually prepares free memory proactively, not wait until memory is full
 - Background thread: [swap daemon](#) or [page daemon](#)
 - When free memory is below the low watermark, it begins to evict pages until free memory becomes above the high watermark
- ✓ Group a number of pages and write them out at once (to make sequential writes for better performance)

■ Summary of Swapping

- ✓ [Larger than physical memory](#)
 - Present bit in PT
 - Page fault handler in OS
- ✓ [Transparent to user](#)
 - Sometimes not (stuck)

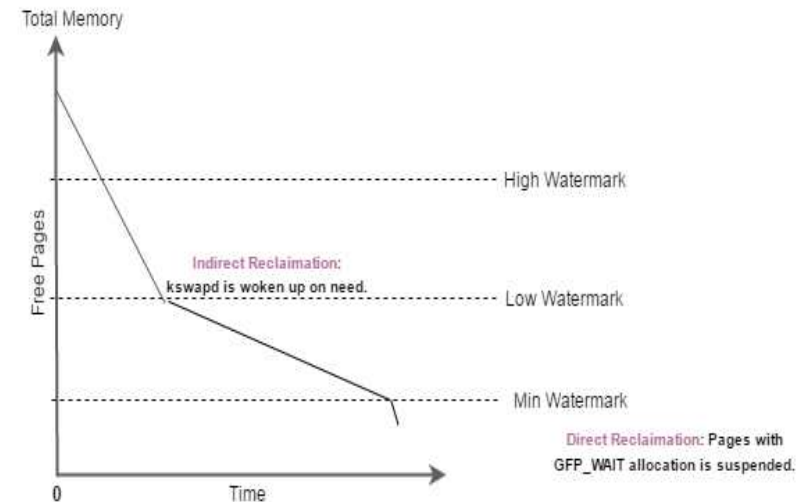

Chap. 24 Summary Dialogue on Memory Virtualization

Student: *(Gulps) Wow, that was a lot of material.*

Professor: *Yes, and?*

Student: *Well, how am I supposed to remember it all? You know, for the exam?*

Professor: *Goodness, I hope that's not why you are trying to remember it.*

Student: *Why should I then?*

Professor: *Come on, I thought you knew better. You're trying to learn something here, so that when you go off into the world, you'll understand how systems actually work.*

Student: *Hmm... can you give an example?*

Professor: *Sure! One time back in graduate school, my friends and I were measuring how long memory accesses took, and once in a while the numbers were way higher than we expected; we thought all the data was fitting nicely into the second-level hardware cache, you see, and thus should have been really fast to access.*

Student: *(nods)*

Professor: *We couldn't figure out what was going on. So what do you do in such a case? Easy, ask a professor! So we went and asked one of our professors, who looked at the graph we had produced, and simply said "TLB". Aha! Of course, TLB misses! Why didn't we think of that? Having a good model of how virtual memory works helps diagnose all sorts of interesting performance problems.*