

Lecture Note 2: Processes

March 16, 2026

Jongmoo Choi

Dept. of Software
Dankook University

<http://embedded.dankook.ac.kr/~choijm>

(본 교재는 2026년도 과학기술정보통신부 및 정보통신기획평가원의 'SW중심대학사업' 지원을 받아 제작 되었습니다.)

Contents

- From Chap 3~6 of the OSTEP
- Chap 3. A Dialogue on Virtualization
- Chap 4. The abstraction: The Process
 - ✓ Process, Process API, Process State and Data Structure
- Chap 5. Interlude: Process API
 - ✓ System calls: fork(), wait(), exec(), kill() , ...
- Chap 6. Mechanism: Limited Direct Execution
 - ✓ Basic Technique: Limited Direct Execution
 - ✓ Switch between Modes
 - ✓ Switch between Processes

Chap 3. A Dialogue on Virtualization

■ Virtualization

Student: But what is virtualization, oh noble professor?

Professor: Imagine we have a peach.

Student: *A peach? (incredulous)*

Professor: *Yes, a peach. Let us call that the **physical** peach. But we have many eaters who would like to eat this peach. What we would like to present to each eater is their own peach, so that they can be happy. We call the peach we give eaters **virtual** peaches; we somehow create many of these virtual peaches out of the one physical peach. And the important thing: in this illusion, it looks to each eater like they have a physical peach, but in reality they don't.*

Student: *So you are sharing the peach, but you don't even know it?*

Professor: *Right! Exactly.*

Student: *But there's only one peach.*

Professor: *Yes. And...?*

Student: *Well, if I was sharing a peach with somebody else, I think I would notice.*

Professor: *Ah yes! Good point. But that is the thing with many eaters; most of the time they are napping or doing something else, and thus, you can snatch that peach away and give it to someone else for a while. And thus we create the illusion of many virtual peaches, one peach for each person!*

Student: *Sounds like a bad campaign slogan. You are talking about computers, right Professor?*

Professor: *Ah, young grasshopper, you wish to have a more concrete example. Good idea! Let us take the most basic of resources, the CPU. Assume there is one physical CPU in a system (though now there are often two or four or more). What virtualization does is take that single CPU and make it look like many virtual CPUs to the applications running on the system. Thus, while each application*

Chap 4. The Abstraction: The Process

■ Process definition

- ✓ A program in execution
- ✓ Scheduling entity (CPU), has its memory (DRAM)
 - c.f.) program: a lifeless thing, sit on the disk and waiting to spring into action
- ✓ There exist multiple processes (e.g. ppt, browser, word, player, ...)
 - Each process has its own memory (address space), virtual CPU, state, ...

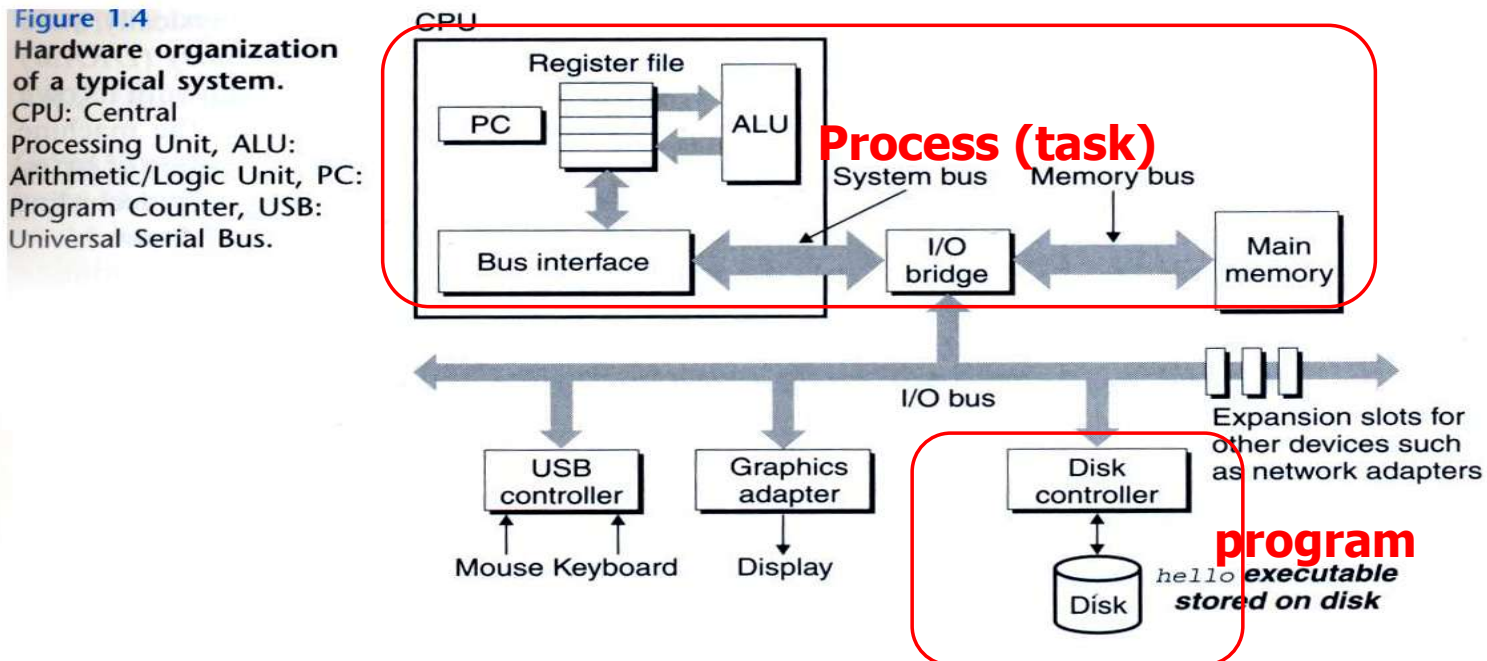

(Source: computer systems: a programmer perspective)

Chap 4. The Abstraction: The Process

■ How to virtualize CPU? Time sharing system

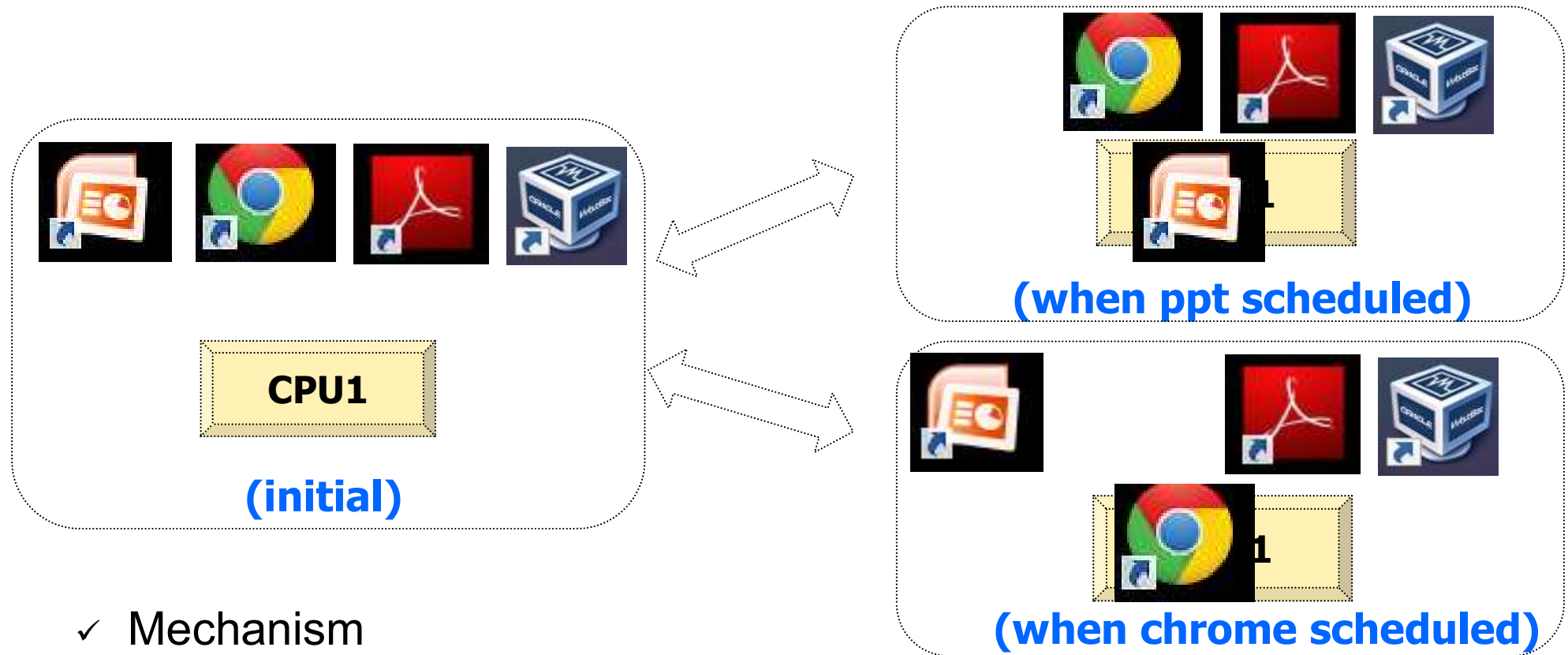

✓ Mechanism

- context switch: an ability to stop running one program and start running another on a given CPU → this LN

✓ Policy

- Scheduling policy: based on historical information or workload knowledge or performance metric → next LN

← Time sharing vs. Space sharing

4.1 Process

■ Process structure

✓ Need resources to run:

- CPU
 - Registers such as PC, SP, ..
- Memory (**address space**)
 - Text: program codes
 - Data: global variables
 - Stack: local variables, parameters, ...
 - Heap: allocated dynamically
- I/O information
 - Opened files (including devices)

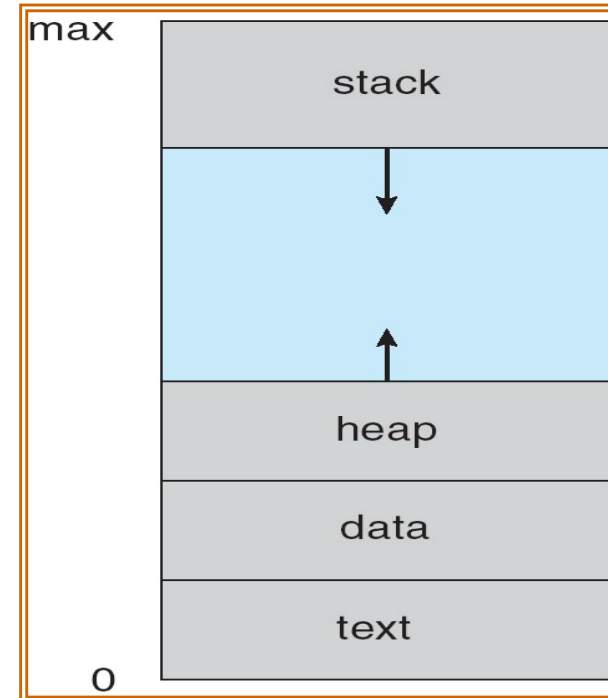

(Source: A. Silberschatz, "Operating system Concept")

✓ Program vs. Process

- Program: passive entity, a file containing instructions stored on disk (executable file or **binary**)
- Process: active entity, having CPU and memory, doing I/Os
- Execute a program twice → result in creating two processes (from one program) → text is equivalent while others (data, stack) vary (**1-to-n**)

4.2 Process API

■ Basic APIs for a process

- **Create:** An operating system must include some method to create new processes. When you type a command into the shell, or double-click on an application icon, the OS is invoked to create a new process to run the program you have indicated.
- **Destroy:** As there is an interface for process creation, systems also provide an interface to destroy processes forcefully. Of course, many processes will run and just exit by themselves when complete; when they don't, however, the user may wish to kill them, and thus an interface to halt a runaway process is quite useful.
- **Wait:** Sometimes it is useful to wait for a process to stop running; thus some kind of waiting interface is often provided.
- **Miscellaneous Control:** Other than killing or waiting for a process, there are sometimes other controls that are possible. For example, most operating systems provide some kind of method to suspend a process (stop it from running for a while) and then resume it (continue it running).
- **Status:** There are usually interfaces to get some status information about a process as well, such as how long it has run for, or what state it is in.

• Related system calls are discussed in the chapter 5 of OSTEP

4.3 Process Execution: A Little More Detail

■ How to start a program

✓ Load

- Bring code and static data into the address space
- Based on executable format (e.g. ELF, PE, BSD, ...)
- **Eagerly** vs. **Lazily** (paging, swapping)

✓ Dynamic allocation

- Stack
- Initialize parameters (argc, argv)
- Heap if necessary

✓ Initialization

- file descriptors (0, 1, 2)
- I/O or signal related structure

✓ Jump to the entry point: main()

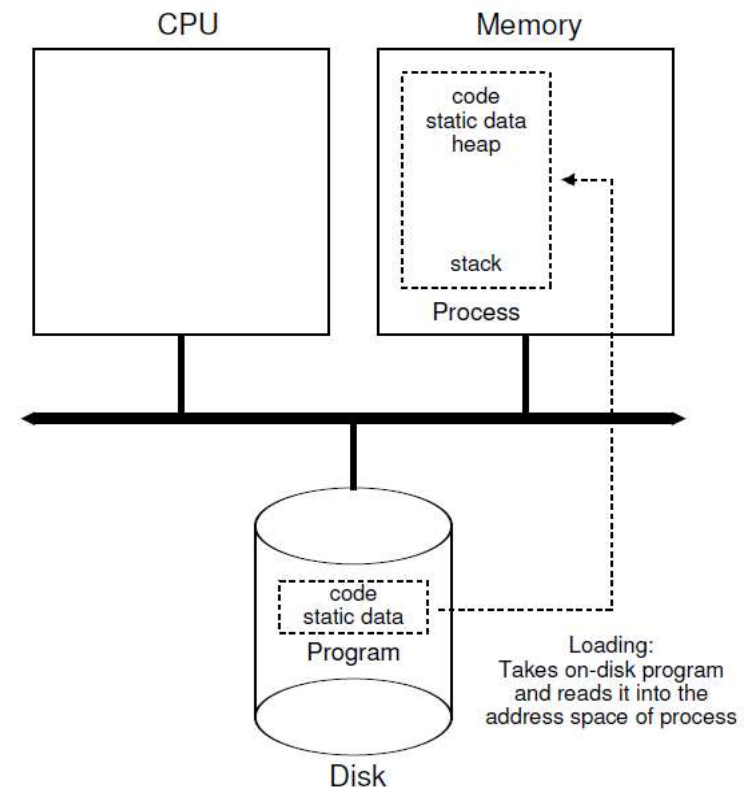
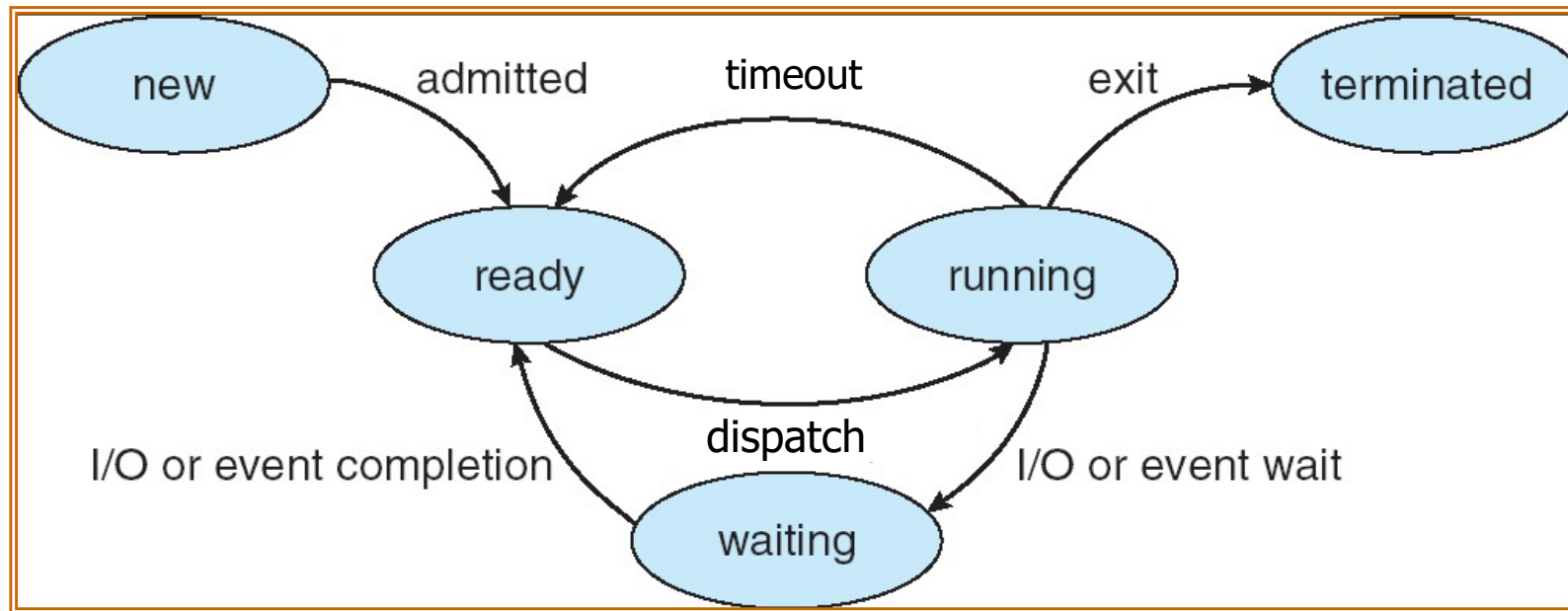

Figure 4.1: Loading: From Program To Process

4.4 Process States

■ State and transition



(Source: A. Silberschatz, "Operating system Concept")

✓ State

- Three cores: ready, running, waiting(**blocked**)
- Two additions: new(created, **embryo**), terminated (**zombie**)

✓ Transition

- dispatch (**schedule**), timeout (**preemptive**, descheduled), wait (**sleep**, I/O initiate), wakeup (I/O done) + admitted, exit
- suspend and resume: to Disk (swap) or to RAM

4.4 Process States

■ Example

- ✓ Used resources: CPU only → Figure 4.3
- ✓ Used resources: CPU and I/O → Figure 4.4
 - Note: I/O usually takes quite longer than CPU

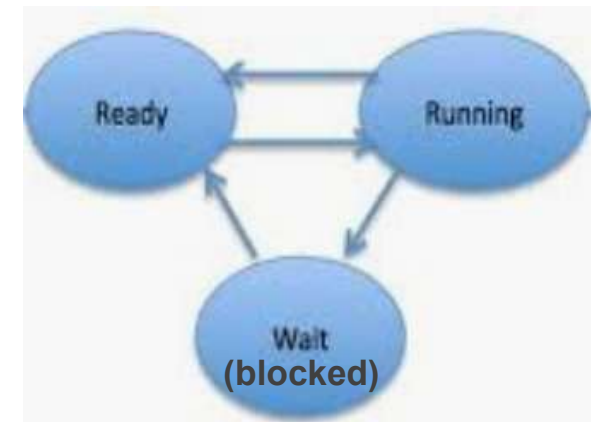

Time	Process ₀	Process ₁	Notes
1	Running	Ready	
2	Running	Ready	
3	Running	Ready	
4	Running	Ready	Process ₀ now done
5	-	Running	
6	-	Running	
7	-	Running	
8	-	Running	Process ₁ now done

Figure 4.3: Tracing Process State: CPU Only

Time	Process ₀	Process ₁	Notes
1	Running	Ready	
2	Running	Ready	
3	Running	Ready	Process ₀ initiates I/O
4	Blocked	Running	Process ₀ is blocked, so Process ₁ runs
5	Blocked	Running	
6	Blocked	Running	
7	Ready	Running	I/O done
8	Ready	Running	Process ₁ now done
9	Running	-	
10	Running	-	Process ₀ now done

Figure 4.4: Tracing Process State: CPU and I/O

➤ At the end of time 6 in Figure 4.4, OS can decide to 1) continue running the process1 or 2) switch back to process 0. Which one is better? Discuss tradeoff.

4.5 Data Structure

■ PCB (Process Control Block)

- ✓ Information associated with each process
 - Process state
 - Process ID (pid)
 - Program counter, CPU registers
 - Used during context switch
 - Architecture dependent
 - CPU scheduling information
 - Memory-management information
 - Opened files
 - I/O status information
 - Accounting information

- ✓ Managed in the kernel's data segment

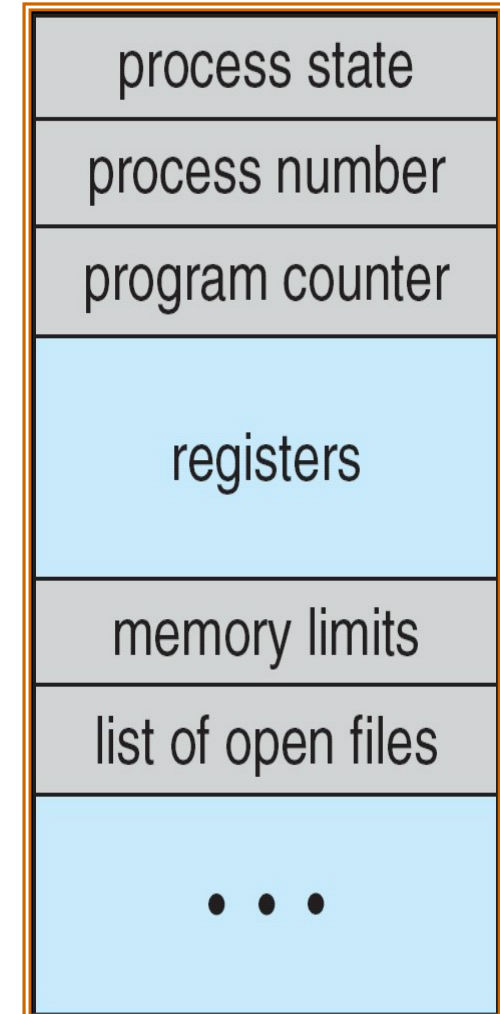

(Source: A. Silberschatz, "Operating system Concept")

4.5 Data Structure

■ PCB Implementation example in OSTEP

- ✓ OS is a program, implementing a process using data structure (e.g. struct proc and struct context)
- ✓ All “proc” structures are manipulated using a list

```
// the registers xv6 will save and restore
// to stop and subsequently restart a process
struct context {
    int eip;
    int esp;
    int ebx;
    int ecx;
    int edx;
    int esi;
    int edi;
    int ebp;
};

// the different states a process can be in
enum proc_state { UNUSED, EMBRYO, SLEEPING,
                  RUNNABLE, RUNNING, ZOMBIE };

// the information xv6 tracks about each process
// including its register context and state
struct proc {
    char *mem;                // Start of process memory
    uint sz;                 // Size of process memory
    char *kstack;            // Bottom of kernel stack
                             // for this process
    enum proc_state state;   // Process state
    int pid;                // Process ID
    struct proc *parent;    // Parent process
    void *chan;             // If non-zero, sleeping on chan
    int killed;             // If non-zero, have been killed
    struct file *ofile[NOFILE]; // Open files
    struct inode *cwd;      // Current directory
    struct context context; // Switch here to run process
    struct trapframe *tf;  // Trap frame for the
                             // current interrupt
};
```

Figure 4.5: The xv6 Proc Structure

4.5 Data Structure (Optional)

■ PCB in real OS (task structure in Linux)

```
818 struct task_struct {
819 #ifdef CONFIG_THREAD_INFO_IN_TASK
820 /*
821  * For reasons of header soup (see current_thread_info()), this
822  * must be the first element of task_struct.
823  */
824 struct thread_info thread_info;
825 #endif
826 unsigned int __state;
827 /* saved state for "spinlock sleepers" */
828 unsigned int saved_state;
829 /*
830  * This begins the randomizable portion of task_struct. Only
831  * scheduling-critical items should be added above here.
832  */
833 randomized_struct_fields_start
834 void *stack;
835 refcount_t usage;
836 /* Per task flags (PF_*), defined further below: */
837 unsigned int flags;
838 unsigned int ptrace;
839 #ifdef CONFIG_MEN_ALLOC_PROFILING
840 struct alloc_tag *alloc_tag;
841 #endif
842 int on_cpu;
843 struct __call_single_node wake_entry;
844 unsigned int wakee_flips;
845 unsigned long wakee_flip_decay_ts;
846 struct task_struct *last_wakee;
847 /*
848  * recent_used_cpu is initially set as the last CPU used by a task
849  * that wakes affine another task. Waker/wakee relationships can
850  * push tasks around a CPU where each wakeup moves to the next one.
851  * Tracking a recently used CPU allows a quick search for a recently
852  * used CPU that may be idle.
853  */
854 int recent_used_cpu;
855 int wake_cpu;
856 int on_rq;
857 int prio;
858 int static_prio;
859 int normal_prio;
860 unsigned int rt_priority;
861 struct sched_entity se;
862 struct sched_rt_entity rt;
863 struct sched_dl_entity dl;
864 struct sched_dl_entity *dl_server;
```

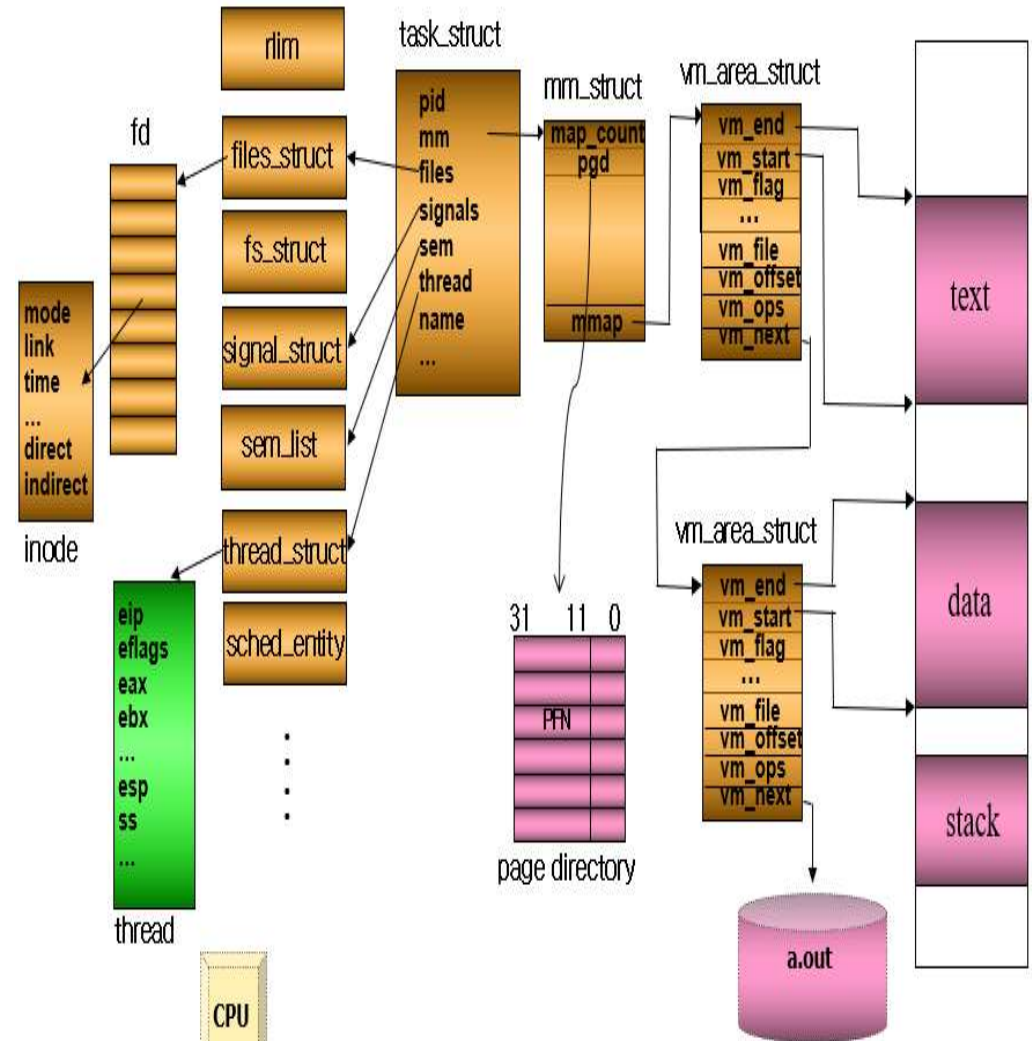

<<https://elixir.bootlin.com/linux/latest/source/include/linux/sched.h>>

(Source: 리눅스 커널 내부구조)

Chap 5. Interlude: Process API

- Comments for Interlude by Remzi

ASIDE: INTERLUDES

Interludes will cover more practical aspects of systems, including a particular focus on operating system APIs and how to use them. If you don't like practical things, you could skip these interludes. But you should like practical things, because, well, they are generally useful in real life; companies, for example, don't usually hire you for your non-practical skills.

5.1 fork() system call

■ fork()

- ✓ Create a new process: parent, child
- ✓ **Return two values**: one for parent (>0) and the other for child (0)
- ✓ Non-determinism: not decide which one run first.

```
2 INTERLUDE: PROCESS API
```

```
1 #include <stdio.h>
2 #include <stdlib.h>
3 #include <unistd.h>
4
5 int main(int argc, char *argv[]) {
6     printf("hello (pid:%d)\n", (int) getpid());
7     int rc = fork();
8     if (rc < 0) {
9         // fork failed
10        fprintf(stderr, "fork failed\n");
11        exit(1);
12    } else if (rc == 0) {
13        // child (new process)
14        printf("child (pid:%d)\n", (int) getpid());
15    } else {
16        // parent goes down this path (main)
17        printf("parent of %d (pid:%d)\n",
18              rc, (int) getpid());
19    }
20    return 0;
21 }
22
```

Figure 5.1: Calling `fork()` (`p1.c`)

5.2 wait() system call

■ wait()

- ✓ Block a calling process until one of its children finishes
- ✓ Now, **deterministic** → synchronization

INTERLUDE: PROCESS API

3

```
1  #include <stdio.h>
2  #include <stdlib.h>
3  #include <unistd.h>
4  #include <sys/wait.h>
5
6  int main(int argc, char *argv[]) {
7      printf("hello (pid:%d)\n", (int) getpid());
8      int rc = fork();
9      if (rc < 0) {          // fork failed; exit
10         fprintf(stderr, "fork failed\n");
11         exit(1);
12     } else if (rc == 0) { // child (new process)
13         printf("child (pid:%d)\n", (int) getpid());
14     } else {              // parent goes down this path
15         int rc_wait = wait(NULL);
16         printf("parent of %d (rc_wait:%d) (pid:%d)\n",
17             rc, rc_wait, (int) getpid());
18     }
19     return 0;
20 }
21
```

Figure 5.2: Calling `fork()` And `wait()` (`p2.c`)

5.3 exec() system call

■ exec()

- ✓ Load and overwrite code and static data, re-initialize stack and heap, and execute it (**never return**) → refer to 8 page
- ✓ 6 variations: execl, execlp, execl, execv, execvp, execve

```
INTERLUDE: PROCESS API 5  
  
1  #include <stdio.h>  
2  #include <stdlib.h>  
3  #include <unistd.h>  
4  #include <string.h>  
5  #include <sys/wait.h>  
6  
7  int main(int argc, char *argv[]) {  
8      printf("hello (pid:%d)\n", (int) getpid());  
9      int rc = fork();  
10     if (rc < 0) { // fork failed; exit  
11         fprintf(stderr, "fork failed\n");  
12         exit(1);  
13     } else if (rc == 0) { // child (new process)  
14         printf("child (pid:%d)\n", (int) getpid());  
15         char *myargs[3];  
16         myargs[0] = strdup("wc"); // program: "wc"  
17         myargs[1] = strdup("p3.c"); // arg: input file  
18         myargs[2] = NULL; // mark end of array  
19         execvp(myargs[0], myargs); // runs word count  
20         printf("this shouldn't print out");  
21     } else { // parent goes down this path  
22         int rc_wait = wait(NULL);  
23         printf("parent of %d (rc_wait:%d) (pid:%d)\n",  
24             rc, rc_wait, (int) getpid());  
25     }  
26     return 0;  
27 }  
28
```

Figure 5.3: Calling fork (), wait (), And exec () (p3.c)

• Comments from Remzi: Do it on a Linux system. "Type in the code and run it is better for understanding"

5.4 Why? Motivating the API (optional)

- Why separate fork() from exec()?
 - ✓ Modular approach of UNIX, support extensibility

```
1  #include <stdio.h>
2  #include <stdlib.h>
3  #include <unistd.h>
4  #include <string.h>
5  #include <fcntl.h>
6  #include <sys/wait.h>
7
8  int main(int argc, char *argv[]) {
9      int rc = fork();
10     if (rc < 0) {
11         // fork failed
12         fprintf(stderr, "fork failed\n");
13         exit(1);
14     } else if (rc == 0) {
15         // child: redirect standard output to a file
16         close(STDOUT_FILENO);
17         open("./p4.output", O_CREAT|O_WRONLY|O_TRUNC,
18             S_IRWXU);
19         // now exec "wc"...
20         char *myargs[3];
21         myargs[0] = strdup("wc"); // program: wc
22         myargs[1] = strdup("p4.c"); // arg: file to count
23         myargs[2] = NULL; // mark end of array
24         execvp(myargs[0], myargs); // runs word count
25     } else {
26         // parent goes down this path (main)
27         int rc_wait = wait(NULL);
28     }
29     return 0;
30 }
```

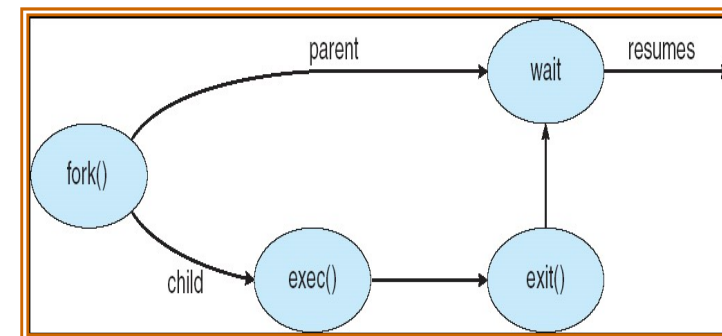

Figure 5.4: All Of The Above With Redirection (p4.c)

5.5 Other parts of the API

■ Other APIs

- ✓ `getpid()`: get process id
- ✓ `kill()`: send a signal to a process
- ✓ `signal()`: register a signal catch function
- ✓ scheduling related
- ✓ ...

■ Command and tool

- ✓ `ps`, `top`, `perf`, ...
- ✓ read the **man pages** for commands and tools

ASIDE: RTFM — READ THE MAN PAGES

Many times in this book, when referring to a particular system call or library call, we'll tell you to read the **manual pages**, or **man pages** for short. Man pages are the original form of documentation that exist on UNIX systems; realize that they were created before the thing called **the web** existed.

Spending some time reading man pages is a key step in the growth of a systems programmer; there are tons of useful tidbits hidden in those pages. Some particularly useful pages to read are the man pages for whichever shell you are using (e.g., `tcsh`, or `bash`), and certainly for any system calls your program makes (in order to see what return values and error conditions exist).

Finally, reading the man pages can save you some embarrassment. When you ask colleagues about some intricacy of `fork()`, they may simply reply: "RTFM." This is your colleagues' way of gently urging you to Read The Man pages. The F in RTFM just adds a little color to the phrase...

Chap 6. Mechanism: Limited Direct Execution

- Time sharing
 - ✓ Key technique for virtualizing CPU
 - ✓ Issues
 - Performance: how to minimize the virtualization overhead?
 - Control: how to run processes while **retaining control** over the CPU?
 - ✓ Solutions
 - Direct execution for performance
 - Limited for control: 1) mode switch using trap, 2) timer interrupt

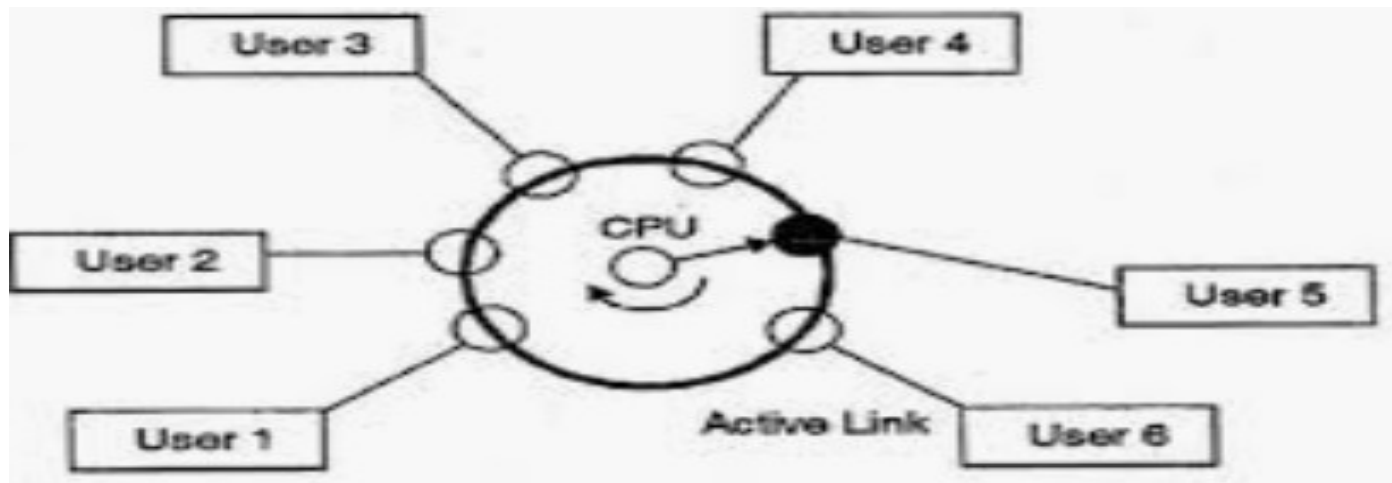

(Source: Google image. Users can be replaced with programs or processes)

6.1 Basic Technique: Limited Direct Execution

■ Background

- ✓ Asynchronous events
 - Events that are not coordinated in time, without global clock, outside of main thread
 - Example: 1) Trap, 2) Interrupt, 3) Signal
- ✓ Trap
 - Asynchronous events to kernel (SW related)
 - Example: system call, divide_by_zero, segmentation fault, page fault, protection fault, ...
 - Trap handlers in Trap table (e.g. syscall handler)
- ✓ Interrupt
 - Asynchronous events to kernel (HW related)
 - Example: keyboard, disk, network card, timer, ...
 - Interrupt handlers in Interrupt table (IVT, usually shared with trap handlers)
- ✓ Signal
 - Asynchronous events to a process
 - Example: SIGKILL, SIGALARM, SIGSTP, SIGCONT, SIGUSR1, ...
 - Signal handlers (Signal catch functions) in Signal table, signal()

6.1 Basic Technique: Limited Direct Execution

- Performance-oriented → Direct execution (Without Limits)
 - ✓ Run the program directly on the CPU
 - ✓ Efficient but not controllable

OS	Program
Create entry for process list	
Allocate memory for program	
Load program into memory	
Set up stack with argc/argv	
Clear registers	
Execute call main()	
	Run main()
	Execute return from main
Free memory of process	
Remove from process list	

Figure 6.1: Direct Execution Protocol (Without Limits)

- **What is the problem of the above example?**
- **Control is particularly important to OS. Without control, a process could run forever, monopolizing resources.**

6.1 Basic Technique: Limited Direct Execution

- Limited: mode switch using trap
 - ✓ Some operations that should run in OS (for control)

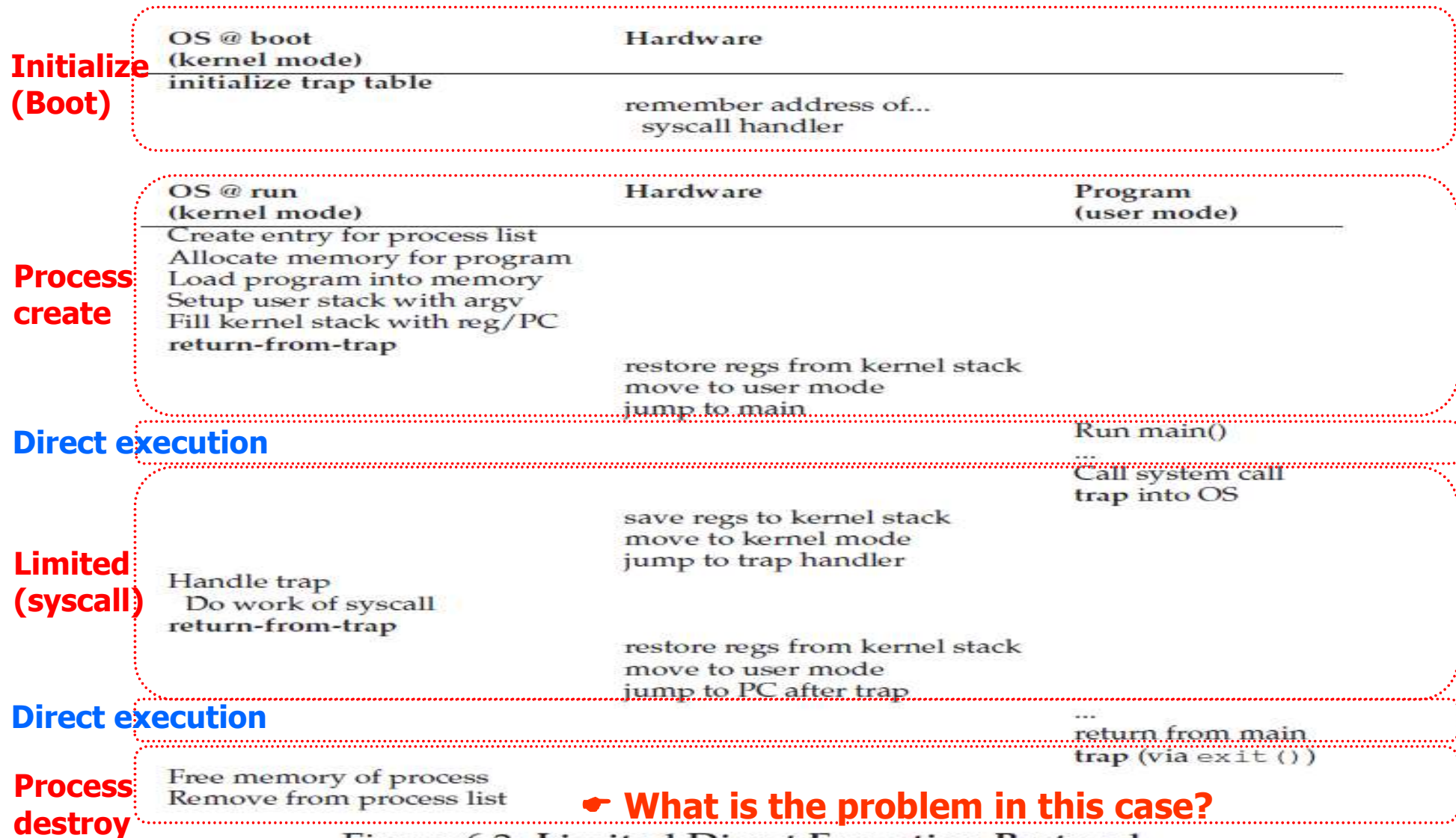

Figure 6.2: Limited Direct Execution Protocol

6.1 Basic Technique: Limited Direct Execution

- Limited: timer interrupt (with context switch in this case)

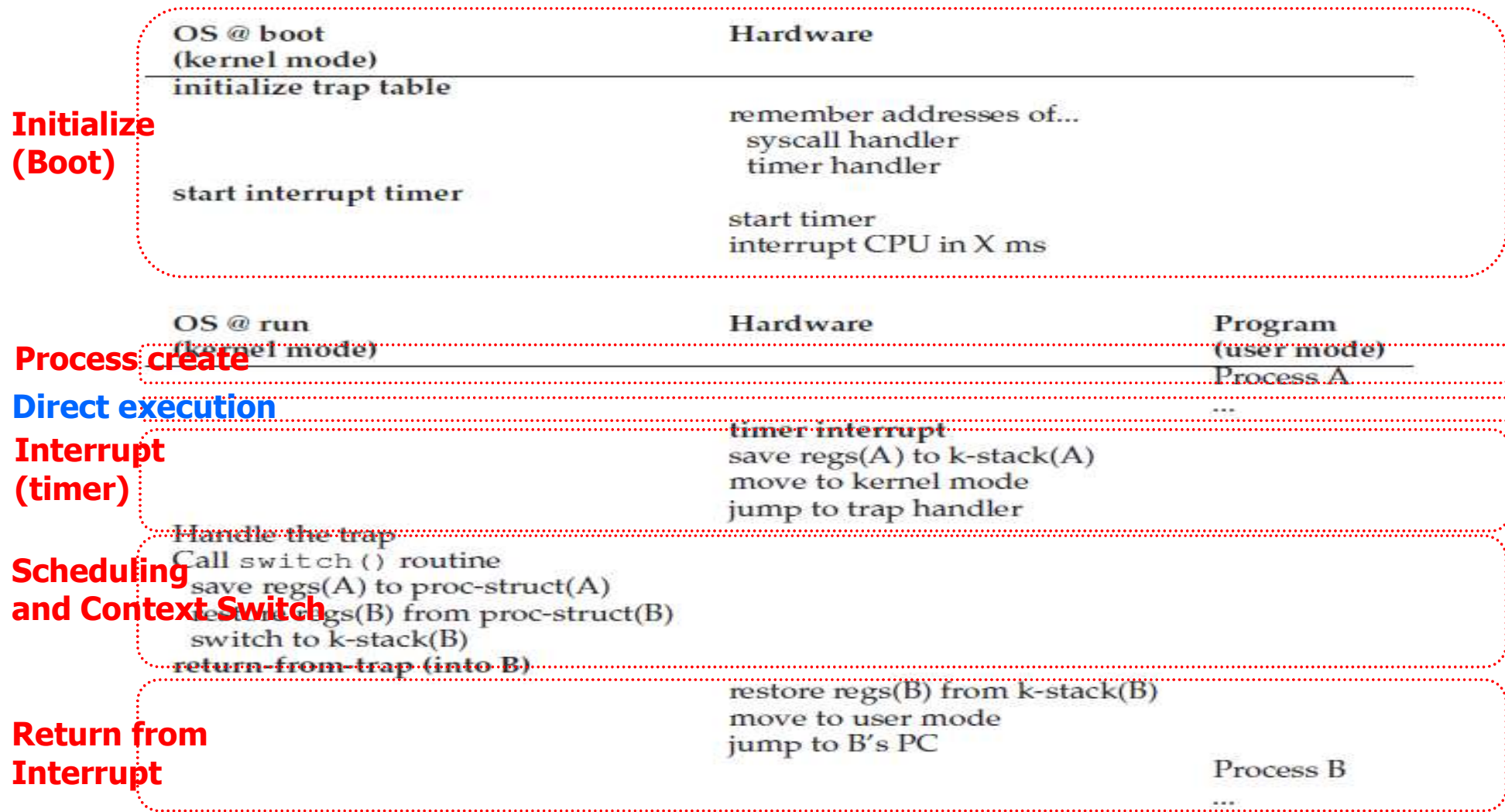
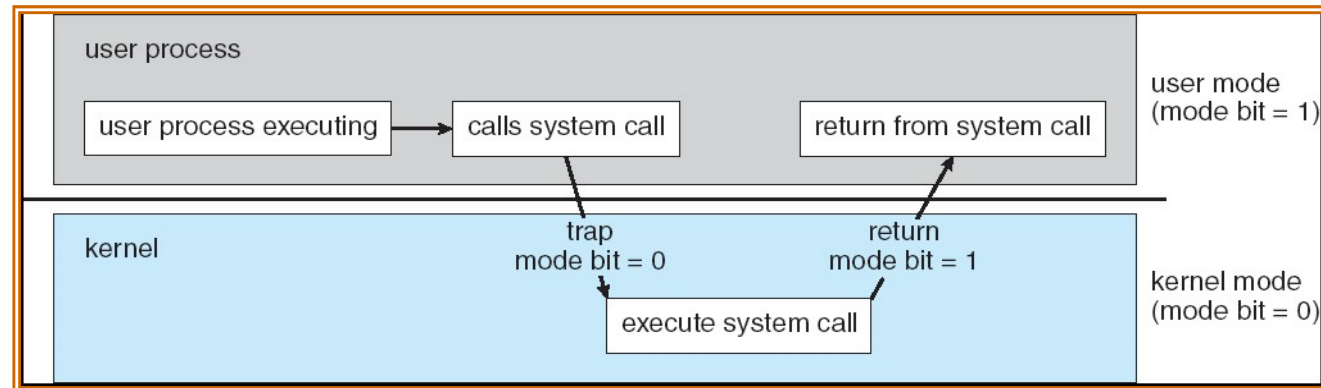

Figure 6.3: Limited Direct Execution Protocol (Timer Interrupt)

6.2 Problem #1: Restricted Operation

- Control mechanism 1: Restrict operations
 - ✓ Most operations can run directly (e.g. arithmetic, loop, branch, ...)
 - ✓ Some operations that should run indirectly (**privileged operations**)
 - Gain more system resources such as CPU and memory
 - Issue an I/O request directly to a disk
 - ✓ Through a well defined APIs (system call)
 - E.g.) fork(), nice(), malloc(), open(), read(), write(), ...
- How to: User mode vs. Kernel mode
 - ✓ User mode: do privileged operation → cause exception and killed
 - ✓ Kernel mode: do privileged operation → allowed
 - ✓ Mode switch: using **trap** instruction, two stacks (user and kernel stack)



(Source: A. Silberschatz, "Operating system Concept")

6.2 Problem #1: Restricted Operation

■ How to handle trap in OS?

- ✓ Using **trap table** (a.k.a IVT, interrupt vector table)
- ✓ Trap table consists of a set of **trap handlers**
 - Trap (interrupt) handler: a routine that deals with a trap in OS
 - system call handler, div_by_zero handler, segment fault handler, page fault handler, and hardware interrupt handler (disk, KBD, timer, ...)
 - Initialized at boot time
- ✓ E.g.: System call processing
 - System call (e.g. fork()) → trap → save context and switch stack → jump to the trap handler → eventually in kernel mode
 - Return from system call → switch stack and restore context → jump to the next instruction of the system call → user mode

0	divide_by_zero()
1	page_fault()
2	segment_fault()
..	...
80	system_call()

trap table

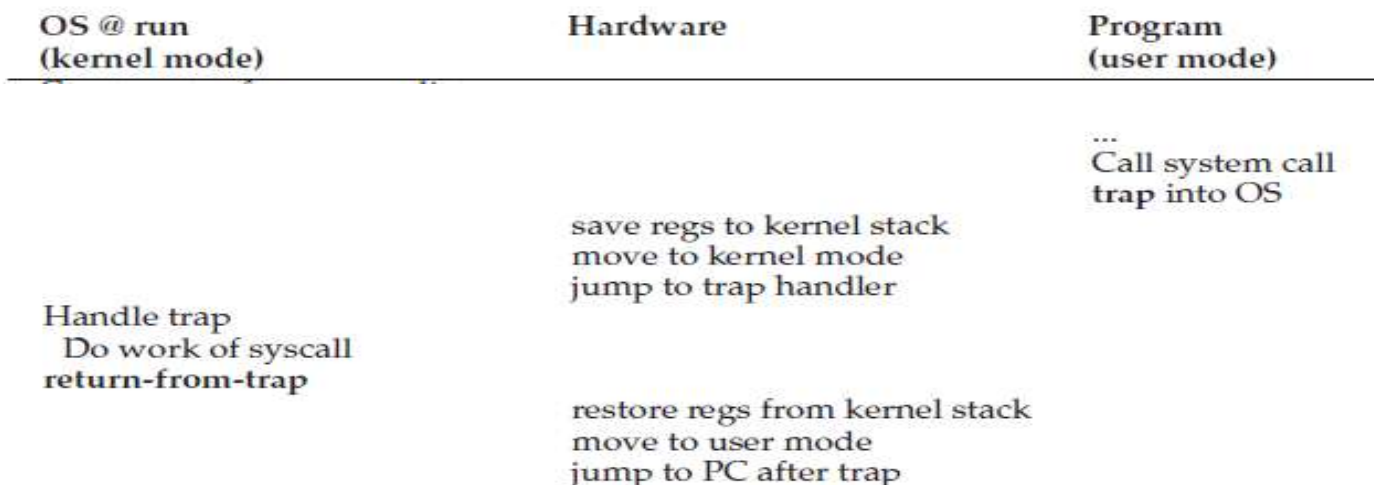

6.2 Problem #1: Restricted Operation (optional)

■ System call Implementation: Linux case study

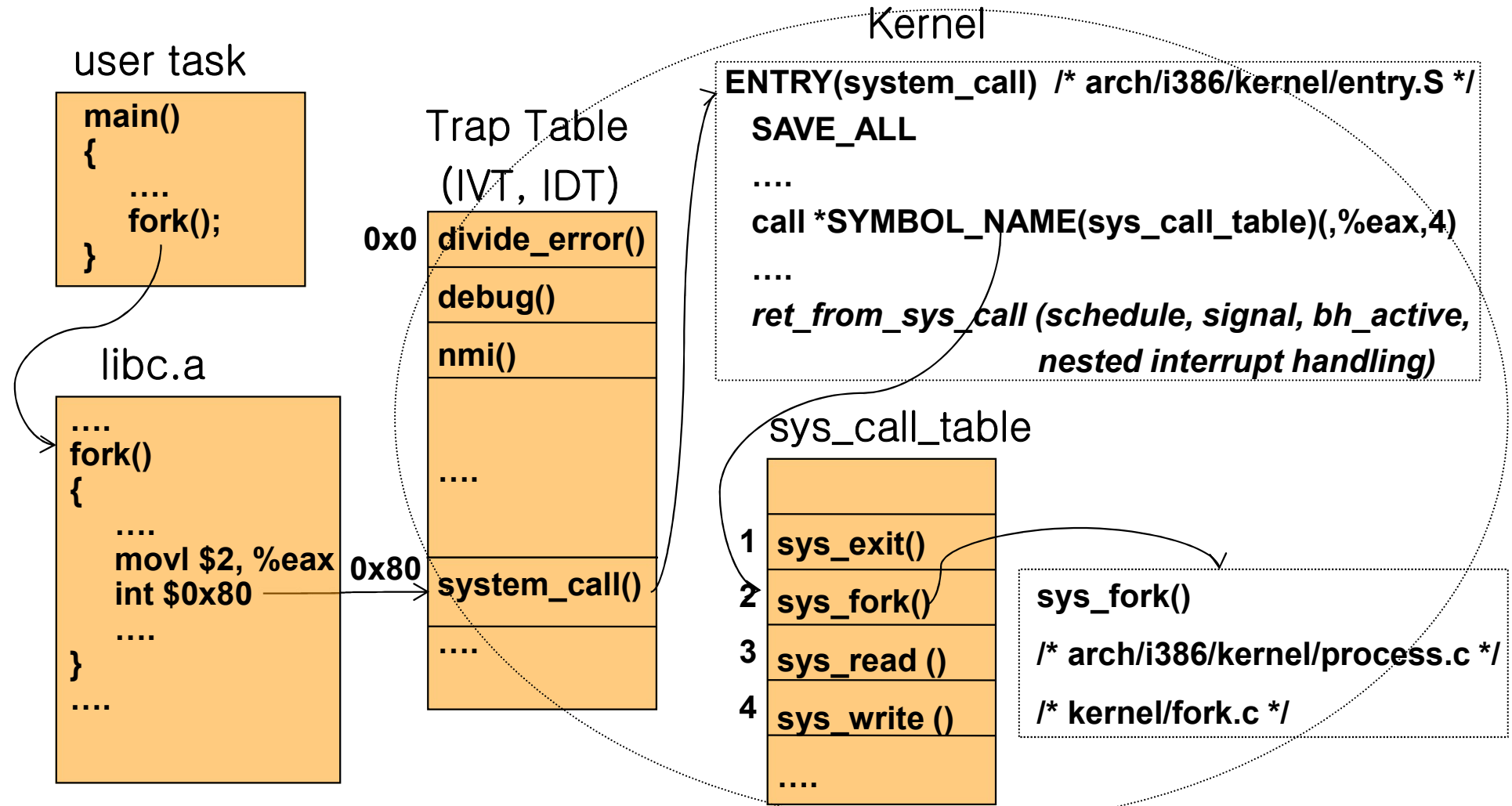

(Source: 리눅스 커널 내부구조, 6장)

➤ Note: This mechanism is a little different in 64bit CPU, but the concept is the same

6.3 Problem #2: Switching between Processes

- Control mechanism 2: using timer interrupt
 - ✓ Interrupt: a mechanism that a device notify an event to OS
 - Interrupt happens → current running process is suspended → a related interrupt handler is invoked via interrupt table → transfer control to OS
 - ✓ Timer interrupt (like a heart in human)
 - A timer device raises an interrupt every milliseconds (programmable) → a timer interrupt handler → do scheduling (and switching) if necessary
- Context switch
 - ✓ Context: information of a process needed when it is re-scheduled later → hardware registers
 - ✓ Context save and restore
 - E.g. 1) Process A → Process B: save the context of the process A and restore the context of process B.
 - 2) later Process B → Process A: save the context of the process B and restore the saved context of process A
 - Where to save: proc structure in general

6.3 Problem #2: Switching between Processes

■ Context switch

- ✓ Memorize the last state of a process when it is preempted
 - Context save (state save): storing CPU registers into PCB (in memory)
 - Context restore (state restore): loading PCB into CPU registers
- ✓ Context-switch time is overhead (the system does no useful work while switching) → utilizing hardware support (**hyper-threading**)

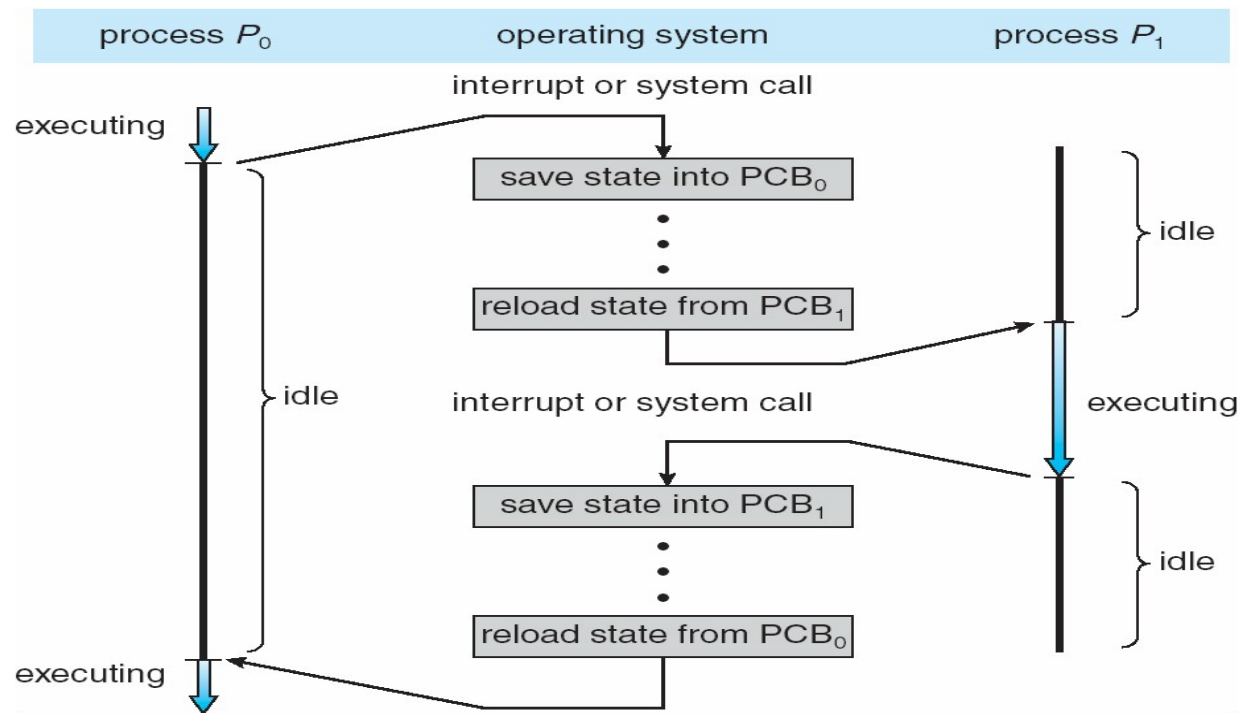

(Source: A. Silberschatz, "Operating system Concept")

6.3 Problem #2: Switching between Processes

■ Context switch: pseudo code

```
1  # void swtch(struct context **old, struct context *new);
2  #
3  # Save current register context in old
4  # and then load register context from new.
5  .globl swtch
6  swtch:
7    # Save old registers
8    movl 4(%esp), %eax # put old ptr into eax
9    popl 0(%eax)      # save the old IP
10   movl %esp, 4(%eax) # and stack
11   movl %ebx, 8(%eax) # and other registers
12   movl %ecx, 12(%eax)
13   movl %edx, 16(%eax)
14   movl %esi, 20(%eax)
15   movl %edi, 24(%eax)
16   movl %ebp, 28(%eax)
17
18   # Load new registers
19   movl 4(%esp), %eax # put new ptr into eax
20   movl 28(%eax), %ebp # restore other registers
21   movl 24(%eax), %edi
22   movl 20(%eax), %esi
23   movl 16(%eax), %edx
24   movl 12(%eax), %ecx
25   movl 8(%eax), %ebx
26   movl 4(%eax), %esp # stack is switched here
27   pushl 0(%eax)      # return addr put in place
28   ret                # finally return into new ctxt
```

Figure 6.4: The xv6 Context Switch Code

6.4 Worried about concurrency?

■ Some issues

- ✓ What happens when you are handling one interrupt and another one occurs?
- ✓ What happen when, during a system call, a timer interrupt occurs?

■ Some solutions

- ✓ Disable interrupt (note: disable interrupt too long is dangerous)
- ✓ Priority
- ✓ Locking mechanism
- ✓ → **actually Concurrency issue**

Summary

- Process (Chapter 4)
 - ✓ Process definition, Process state
 - ✓ Process management (PCB, struct proc, struct task)
- Process manipulation (Chapter 5)
 - ✓ fork(), wait(), exec(), kill() , ...
- Mechanism (Chapter 6)
 - ✓ Limited Direct Execution: Trap or Interrupt
 - Trigger mode switch (same process) always, and trigger context switch (different processes) if necessary
 - ✓ Key terms

ASIDE: KEY CPU VIRTUALIZATION TERMS (MECHANISMS)

- The CPU should support at least two modes of execution: a restricted **user mode** and a privileged (non-restricted) **kernel mode**.
- Typical user applications run in user mode, and use a **system call** to trap into the kernel to request operating system services.
- The trap instruction saves register state carefully, changes the hardware status to kernel mode, and jumps into the OS to a pre-specified destination: the **trap table**.
- When the OS finishes servicing a system call, it returns to the user program via another special **return-from-trap** instruction, which reduces privilege and returns control to the instruction after the trap that jumped into the OS.
- The trap tables must be set up by the OS at boot time, and make sure that they cannot be readily modified by user programs. All of this is part of the **limited direct execution** protocol which runs programs efficiently but without loss of OS control.
- Once a program is running, the OS must use hardware mechanisms to ensure the user program does not run forever, namely the **timer interrupt**. This approach is a **non-cooperative** approach to CPU scheduling.
- Sometimes the OS, during a timer interrupt or system call, might wish to switch from running the current process to a different one, a low-level technique known as a **context switch**.



Quiz for this Lecture

Quiz

- ✓ 1. Process is defined as a running program. Discuss what information are managed in PCB (Process Control Block).
- ✓ 2. Discuss the state of the parent and child process in the below left program just after line 8, 13 and 16, respectively. (assume that the parent is scheduled before the child)
- ✓ 3. Discuss the differences between trap and interrupt.
- ✓ 4. Discuss how many mode switch and context switch happen in the below right figure.

INTERLUDE: PROCESS API

```

1 #include <stdio.h>
2 #include <stdlib.h>
3 #include <unistd.h>
4 #include <sys/wait.h>
5
6 int main(int argc, char *argv[]) {
7     printf("hello (pid:%d)\n", (int) getpid());
8     int rc = fork();
9     if (rc < 0) { // fork failed; exit
10        fprintf(stderr, "fork failed\n");
11        exit(1);
12    } else if (rc == 0) { // child (new process)
13        printf("child (pid:%d)\n", (int) getpid());
14    } else { // parent goes down this path
15        int rc_wait = wait(NULL);
16        printf("parent of %d (rc_wait:%d) (pid:%d)\n",
17               rc, rc_wait, (int) getpid());
18    }
19    return 0;
20 }

```

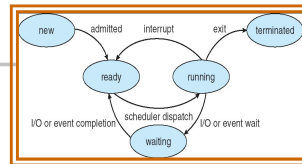

TRAP VERSUS INTERRUPT

TRAP	INTERRUPT
A signal raised from a user program that indicates the operating system to perform on some functionality immediately	A signal to the processor emitted by hardware indicating an event that needs immediate attention
Generated by an instruction in the user program	Generated by hardware devices
Invokes OS functionality - it transfers the control to the trap handler	Triggers the processor to execute the corresponding interrupt handler routine
Synchronous and can arrive after the execution of any instruction	Asynchronous and can occur at the execution of any instruction
Also called a software interrupt	Also called a hardware interrupt

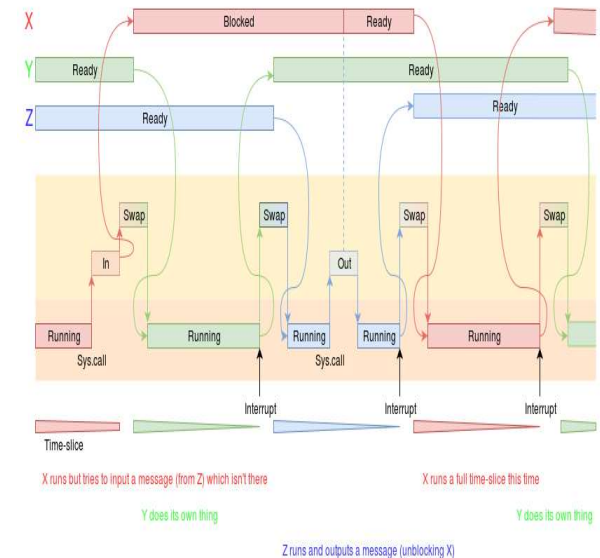

Figure 5.2: Calling fork () And wait () (p2.c)

(Source: pediaa.com/difference-between-trap-and-interrupt/)

(Source: xerxes.cs.manchester.ac.uk/comp251/kb/Context_Switching/)

Suggestion

- Read the questions in OSTEP Chapter 5 (homework) and Chapter 6 (Measurement homework)
 - ✓ Exercise them in a Linux machine (Ubuntu on Virtual box or server)

14

INTERLUDE: PROCESS API

ASIDE: CODING HOMEWORKS

Coding homeworks are small exercises where you write code to run on a real machine to get some experience with some basic operating system APIs. After all, you are (probably) a computer scientist, and therefore should like to code, right? If you don't, there is always CS theory, but that's pretty hard. Of course, to truly become an expert, you have to spend more than a little time hacking away at the machine; indeed, find every excuse you can to write some code and see how it works. Spend the time, and become the wise master you know you can be.

Homework (Code)

In this homework, you are to gain some familiarity with the process management APIs about which you just read. Don't worry – it's even more fun than it sounds! You'll in general be much better off if you find as much time as you can to write some code, so why not start now?

Questions

1. Write a program that calls `fork()`. Before calling `fork()`, have the main process access a variable (e.g., `x`) and set its value to something (e.g., 100). What value is the variable in the child process? What happens to the variable when both the child and parent change the value of `x`?
2. Write a program that opens a file (with the `open()` system call) and then calls `fork()` to create a new process. Can both the child and parent access the file descriptor returned by `open()`? What happens when they are writing to the file concurrently, i.e., at the same time?
3. Write another program using `fork()`. The child process should print "hello"; the parent process should print "goodbye". You should try to ensure that the child process always prints first; can you do this *without* calling `wait()` in the parent?
4. Write a program that calls `fork()` and then calls some form of `exec()` to run the program `/bin/ls`. See if you can try all of the variants of `exec()`, including (on Linux) `execl()`, `execle()`, `execlp()`, `execvp()`, `execvpe()`, and `execvppe()`. Why do you think there are so many variants of the same basic call?

16

MECHANISM: LIMITED DIRECT EXECUTION

Homework (Measurement)

ASIDE: MEASUREMENT HOMEWORKS

Measurement homeworks are small exercises where you write code to run on a real machine, in order to measure some aspect of OS or hardware performance. The idea behind such homeworks is to give you a little bit of hands-on experience with a real operating system.

In this homework, you'll measure the costs of a system call and context switch. Measuring the cost of a system call is relatively easy. For example, you could repeatedly call a simple system call (e.g., performing a 0-byte read), and time how long it takes; dividing the time by the number of iterations gives you an estimate of the cost of a system call.

One thing you'll have to take into account is the precision and accuracy of your timer. A typical timer that you can use is `gettimeofday()`; read the man page for details. What you'll see there is that `gettimeofday()` returns the time in microseconds since 1970; however, this does not mean that the timer is precise to the microsecond. Measure back-to-back calls to `gettimeofday()` to learn something about how precise the timer really is; this will tell you how many iterations of your null system-call test you'll have to run in order to get a good measurement result. If `gettimeofday()` is not precise enough for you, you might look into using the `rdtsc` instruction available on x86 machines.

Measuring the cost of a context switch is a little trickier. The `lmbench`

Appendix

■ Answers for questions commonly asked by students

```

1 #include <unistd.h>
2 #include <stdio.h>
3 #include <stdlib.h>
4 #include "common.h"
5
6 int
7 main(int argc, char *argv[])
8 {
9     int *p = malloc(sizeof(int));           // a1
10    assert(p != NULL);
11    printf("(%) address pointed to by p: %p\n",
12           getpid(), p);                   // a2
13    *p = 0;                                 // a3
14    while (1) {
15        Spin(1);
16        *p = *p + 1;
17        printf("(%) p: %d\n", getpid(), *p); // a4
18    }
19    return 0;
20 }

```

Figure 2.3: A Program That Accesses Memory (mem.c)

```

prompt> ./mem & ./mem &
[1] 24113
[2] 24114
(24113) address pointed to by p: 0x200000
(24114) address pointed to by p: 0x200000
(24113) p: 1
(24114) p: 1
(24114) p: 2
(24113) p: 2
(24113) p: 3
(24114) p: 3
(24113) p: 4
(24114) p: 4
...

```

Figure 2.4: Running The Memory Program Multiple Times

(Source: Chapter 2 in OSTEP)

- ✓ Q1: same address in the two processes?
- ✓ Q2: why not 1 → 2 → 3 → 4 → ...
- ✓ Key concept: Program → CPU using **Compiler** and **OS**

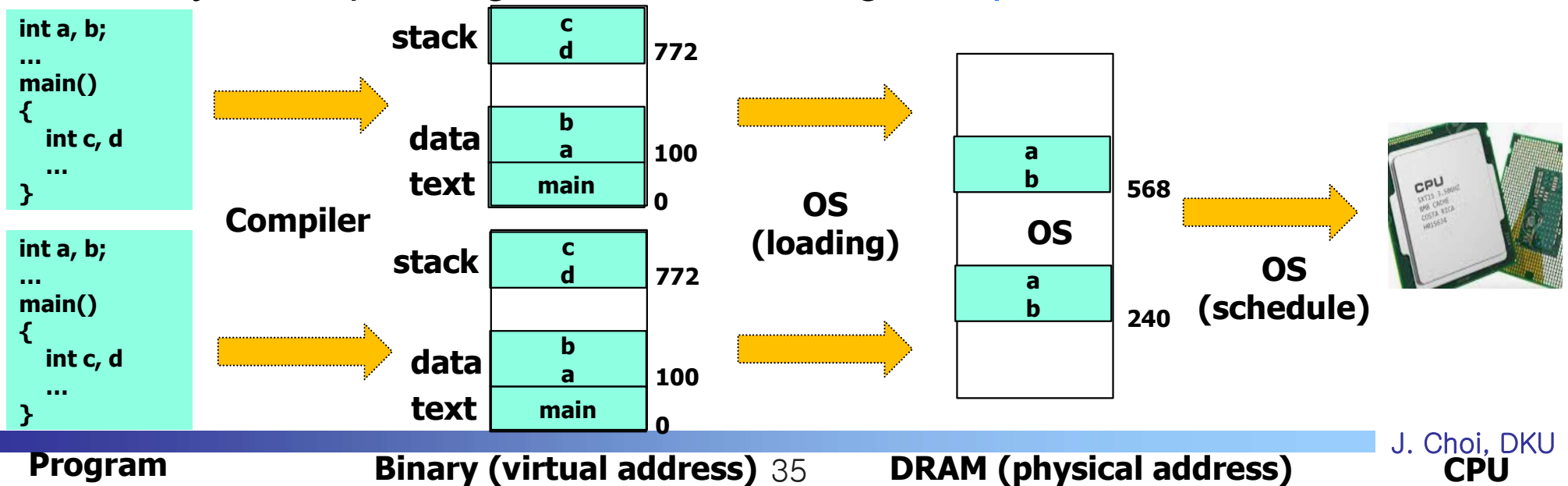

사사

- 본 교재는 2026년도 과학기술정보통신부 및 정보통신기획평가원의 ‘SW중심대학사업’ 지원을 받아 제작 되었습니다.
- 본 결과물의 내용을 전재할 수 없으며, 인용(재사용)할 때에는 반드시 과학기술정보통신부와 정보통신기획평가원이 지원한 ‘SW중심대학’의 결과물이라는 출처를 밝혀야 합니다.

IITP 정보통신기획평가원
디지털인재양성단 SW인재팀

SW중심대학이 무엇인가요?

SW중심대학은
대학교육을 SW중심으로 혁신함으로써,
SW전문인력을 양성하고
학생·기업·사회의 SW경쟁력을 강화해
진정한 SW가치 확산을 실현하는 대학을 말합니다.

