

# Lecture Note 3. Scheduling

March 23, 2026

Jongmoo Choi

Dept. of Software  
Dankook University

<http://embedded.dankook.ac.kr/~choijm>

(본 교재는 2026년도 과학기술정보통신부 및 정보통신기획평가원의 'SW중심대학사업' 지원을 받아 제작 되었습니다.)

# Contents

---

- From Chap 7~11 of the OSTEP
- Chap 7. Scheduling: Introduction
  - ✓ Workload assumptions and Scheduling Metrics
  - ✓ Algorithms: FIFO, SJF, STCF, RR
  - ✓ Incorporating I/O
- Chap 8. Scheduling: MLFQ (Multi-Level Feedback Queue)
  - ✓ Basic rules
  - ✓ Attempts: Change priority, Boost priority, Better accounting
  - ✓ Tuning MLFQ and other issues
- Chap 9. Scheduling: Proportional Share
  - ✓ Basic concept: Lottery, Stride
  - ✓ Ticket mechanism, implementation, example and issues
- Chap 10. Multiprocessor Scheduling
  - ✓ Background: load balancing, cache affinity
  - ✓ Scheduling: single queue, multi-queue
- Chap 11. Summary Dialogue on CPU virtualization

# Chap 7. Scheduling: Introduction

## ■ Scheduling

- ✓ Multiple actors want to use (limited) resources at a time
- ✓ Make order to select actors who can use the resources

## ■ Process Scheduling

- ✓ Actor: process, Resource: CPU
- ✓ Select a process who run on a CPU (or CPUs, e.g. gang scheduling)

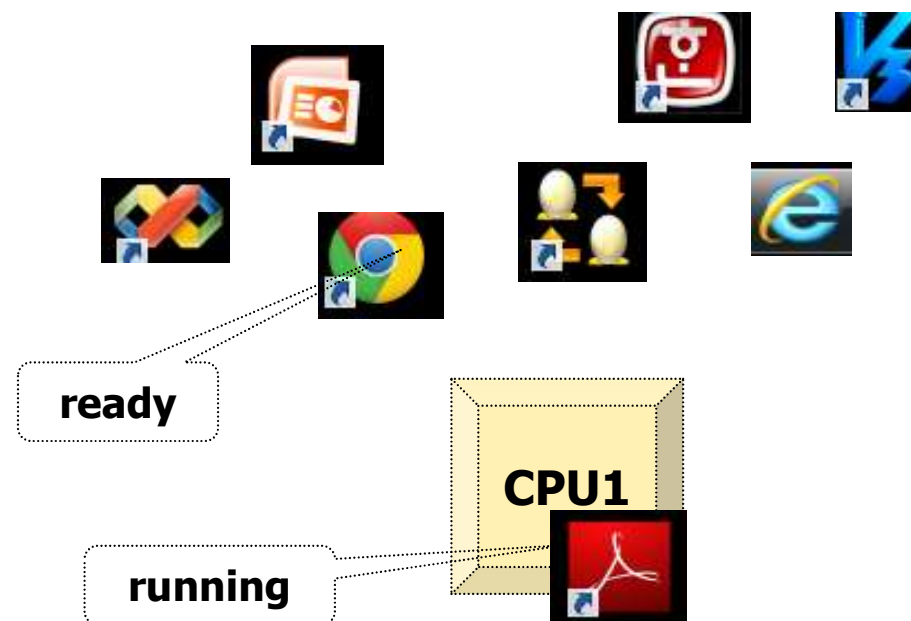

➡ Ready processes are in a queue (called ready queue) like humans

# 7.1 Workload assumption

---

## ■ Workload

- ✓ The amount of work to be done (dictionary)
  - ✓ How much resources are required by a set of processes with the consideration of their characteristics (in computer science)
- 
- A simple assumption about processes (also called as job in the scheduling research area)
    - ✓ All jobs arrives at the same time
    - ✓ Once started, each job runs to completion
    - ✓ All jobs only use the CPU (no I/O)
    - ✓ Each job runs for the same amount of time
    - ✓ The run-time of each job is known in advance
    - ✓ c.f.) unrealistic, but we will relax them as we go

# 7.2 Scheduling Metrics

## ■ Metrics

- ✓ Something that we use to measure (e.g. performance, reliability, ...)

## ■ Metrics for scheduling

- ✓ Turnaround time

- $T_{\text{turnaround}} = T_{\text{completion}} - T_{\text{arrival}}$

- ✓ Response time

- $T_{\text{response}} = T_{\text{firstrun}} - T_{\text{arrival}}$

- ✓ Fairness

- E.g.)  $T_{\text{completion}}$  of P1 vs. that of P2

- ✓ Throughput

- E.g.) number of completed processes / 1 hour (or second or day)

- ✓ Deadline

- E.g.)  $T_{\text{turnaround}} < T_{\text{deadline}}$

- ✓ .....

➤ What do you think first when we choose a restaurant for lunch? (among above)

➤ What does the owner of the restaurant think first?

## 7.3 FIFO (First In, First Out)

### ■ 1. FIFO

✓ Schedule a process that arrives first (a.k.a **FCFS** (First Come First Serve))

✓ Example

- 1) three processes: A, B, C, 2) run-time: 10 seconds, 3) arrival time: 0s (tie-break rule: alphabet in this example)

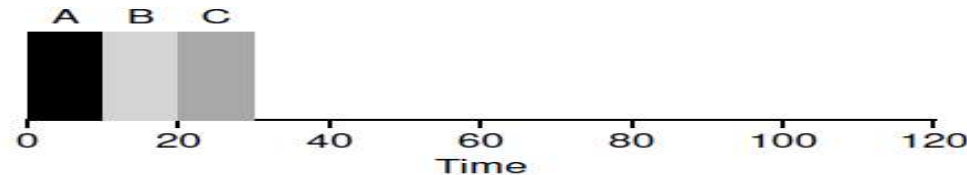

Figure 7.1: FIFO Simple Example

- What is the average turnaround time?

✓ Another example

- 1) three processes: A, B, C, 2) run-time: 100s for A, 10s for B and C

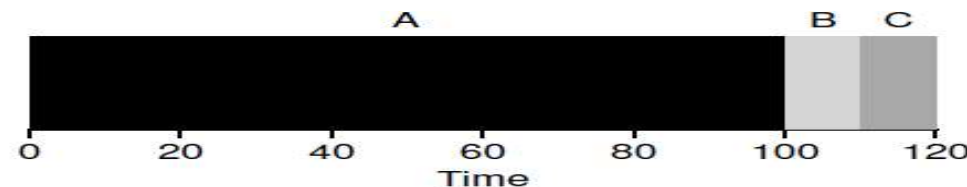

Figure 7.2: Why FIFO Is Not That Great

- Now, what is the average turnaround time?

# 7.3 FIFO (First In, First Out)

## ■ 1. FIFO

### ✓ Pros)

- 1) Clearly simple, 2) Easy to implement

### ✓ Cons)

- 1) May cause a long waiting time (known as **convoy effect**)

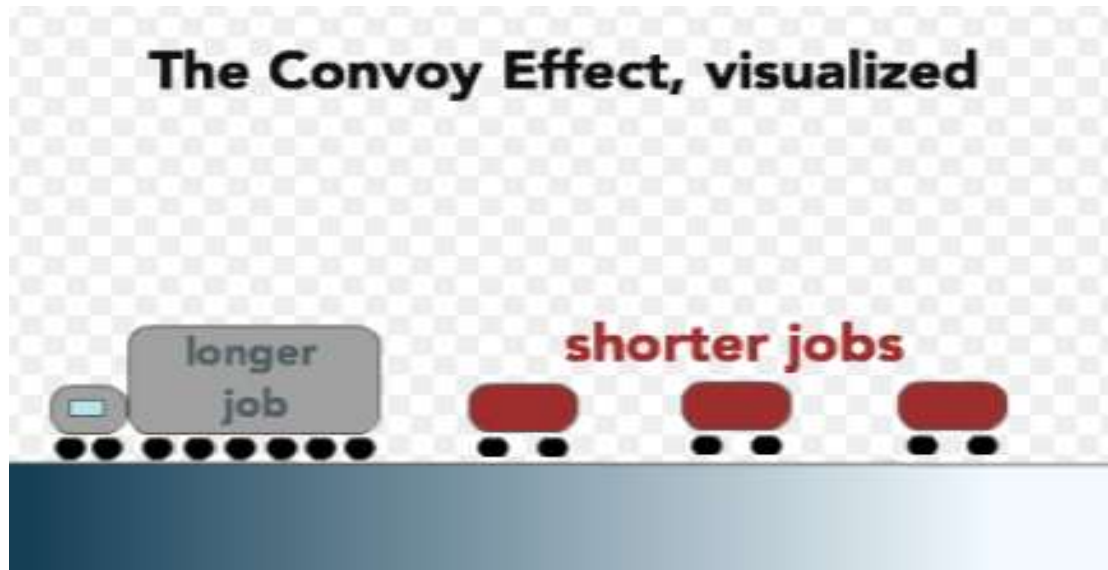

(Source: <http://web.cs.ucla.edu/classes/fall14/cs111/scribe/7a/index.html>)

• How can we overcome this long waiting?

# 7.4 SJF (Shortest Job First)

## ■ 2. SJF

- ✓ Give a higher priority to the shortest job (a.k.a Shortest Process Next (SPN))
  - “ten-items-or-less” in a grocery store
- ✓ Revisit the previous example again
  - 1) three processes: A, B, C, 2) run-time: 100s for A, 10s for B and C



Figure 7.3: SJF Simple Example

- What is the average turnaround time?
- ✓ Pros)
  - Proved as an optimal algorithm
- ✓ Cons)
  - What if B and C arrive a little bit late than A? (e.g. assume 10, not 0)

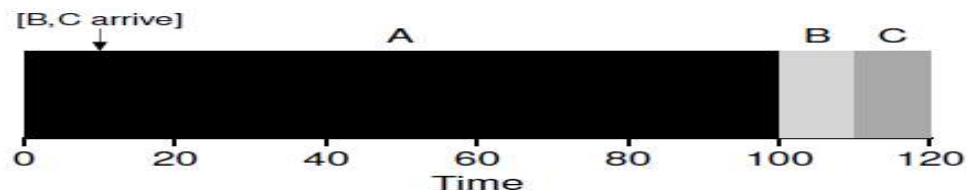

Figure 7.4: SJF With Late Arrivals From B and C

# 7.5 STCF (Shortest Time-to-Completion First)

## ■ 3. STCF

✓ Similar to SJF, but **preemptive** version (a.k.a Shortest Remaining-Time next (SRT))

✓ 1) **Non-preemptive scheduling**

▪ Run a job to completion

✓ 2) **Preemptive scheduling**

▪ Can stop a job (even though it is not completed yet) to run another job

▪ All modern schedulers are preemptive

▪ Require the **context switch**

✓ **Example**

▪ 1) three processes: A, B, C, 2) run-time: 100s for A, 10s for B and C, 3) arrival time: 0s for A, 10s for B and C.

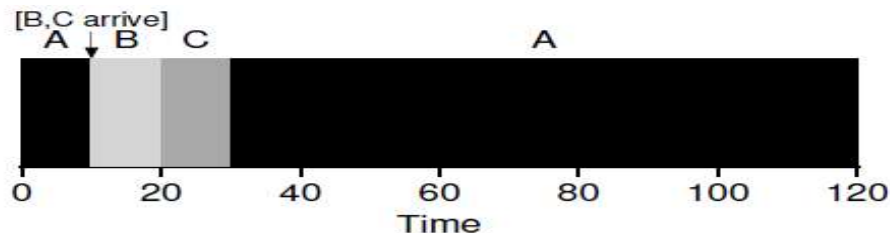
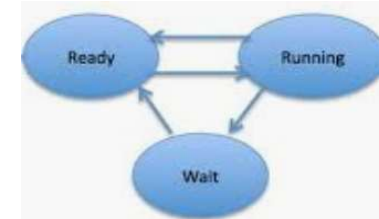

Figure 7.5: STCF Simple Example

VS

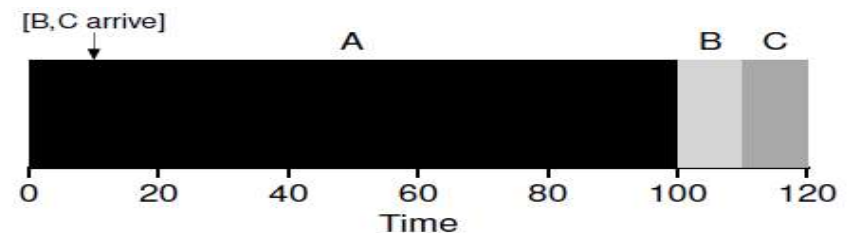

Figure 7.4: SJF With Late Arrivals From B and C

## 7.6 Response time

- Turnaround time
  - ✓ A good metric for a batching system
- Response time
  - ✓ More important for an interactive system?
    - User would sit at a terminal, working something interactively (e.g. move a mouse, type in a letter, visit a site, and so on)
- Revisit the example with SJF (also FIFO)
  - ✓ 1) three processes: A, B, C, 2) run-time: 5 seconds, 3) arrival time: 0s (tie-break rule: alphabet in this example)

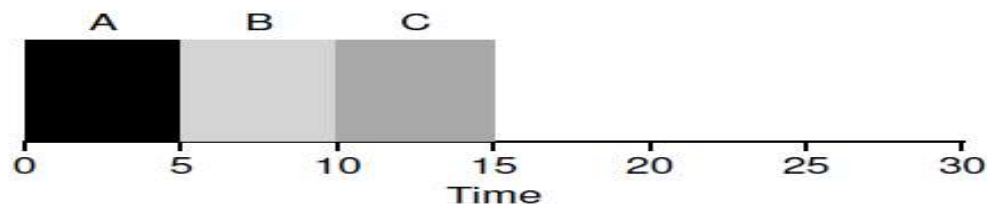

Figure 7.6: SJF Again (Bad for Response Time)

- ✓ What is the average turnaround time?
- ✓ How about the average response time?

✎ Imagine that you move a mouse and wait for a 5s.

# 7.7 RR (Round-robin)

## ■ 4. RR

- ✓ Instead of running a job to completion, it runs a job for a **time slice** (sometimes called a **time quantum, scheduling quantum**) and switch to the next job in the run queue
- ✓ Repeatedly switch jobs until jobs are finished
- ✓ Example
  - 1) three processes: A, B, C, 2) run-time: 5s, 3) arrival time: 0s (same to the previous slide)
  - RR with time slice = 1s (different here: non-preemptive in the previous slide)
  - What is the average response time?
  - What is the average turnaround time?

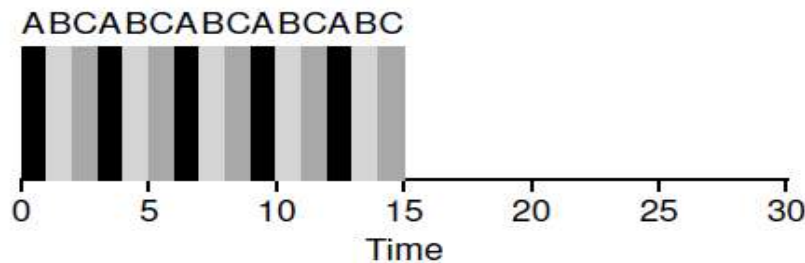

VS

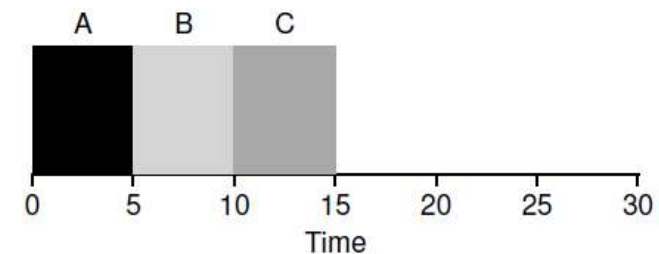

Figure 7.7: Round Robin (Good for Response Time)

Figure 7.6: SJF Again (Bad for Response Time)

➡ What if the time slice is set as 500ms or 100ms or 10ms. Discuss tradeoff

# 7.7 RR (Round-robin)

## ■ Tradeoff of time slice (time quantum)

- ✓ Small: good responsiveness, high context switch overhead
- ✓ Large: low context switch overhead, bad responsiveness
- ✓ We need to balance the tradeoff
  - Good response time with reasonable overhead
  - E.g. time slice: 10ms (or 100ms), context switch overhead: 1ms

### TIP: AMORTIZATION CAN REDUCE COSTS

The general technique of **amortization** is commonly used in systems when there is a fixed cost to some operation. By incurring that cost less often (i.e., by performing the operation fewer times), the total cost to the system is reduced. For example, if the time slice is set to 10 ms, and the context-switch cost is 1 ms, roughly 10% of time is spent context switching and is thus wasted. If we want to *amortize* this cost, we can increase the time slice, e.g., to 100 ms. In this case, less than 1% of time is spent context switching, and thus the cost of time-slicing has been amortized.

## ■ Tradeoff between response time and turnaround time

- ✓ Traditional issue in computer science: interactivity vs performance
- ✓ You can not have your cake and eat it too.
- Question, "explain which process you prefer to schedule when there are two processes, browser and backup apps" → Considerations: 1) interactive or batch, 2) importance, 3) fairness, 4) real-time, ...

# 7.8 Incorporating I/O

- Most of applications do I/Os
  - ✓ Example
    - Two jobs A and B, both need 50ms of CPU time
    - A runs for 10 ms and then issue an I/O request (it takes 10 ms)
  - ✓ What to do while performing I/Os?
    - **Busy waiting**: Figure 7.8
    - **Blocked**: Figure 7.9
  - ✓ How to implement the Figure 7.9

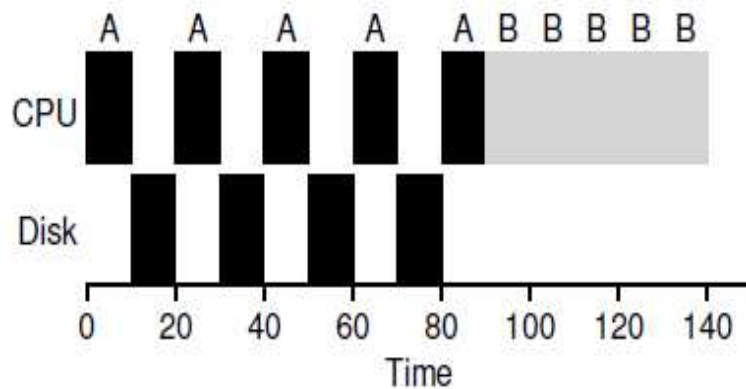
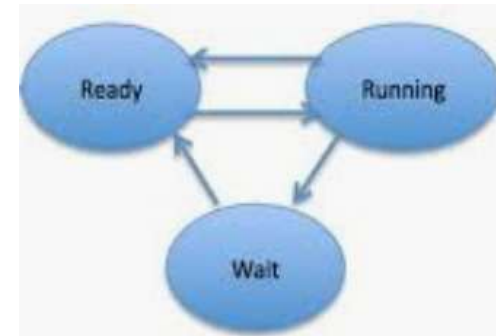

Figure 7.8: Poor Use of Resources

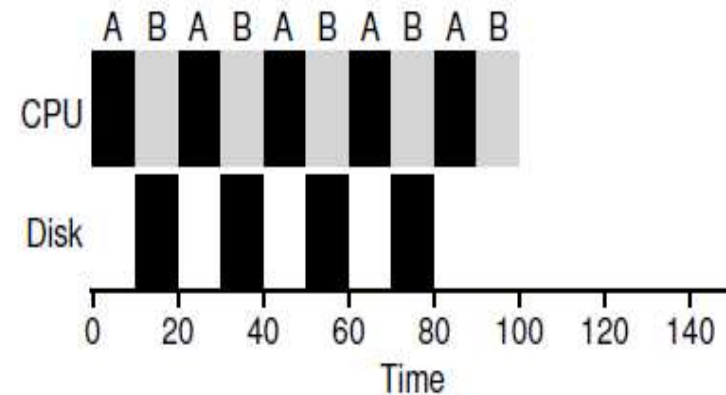

Figure 7.9: Overlap Allows Better Use of Resources

# 8. MLFQ

- Existing scheduling policies
  - ✓ FIFO (6 page), SJF (8 page), STCF(9 page): good for turnaround time, terrible for response time
  - ✓ RR (11 page): vice versa
- How to optimize the turnaround time while minimizing response time?
  - ✓ MLFQ (Multi-Level Feedback Queue)
    - By F. Corbato (Turing Award Winner)
    - Approach: Learn from the past to predict the future (feedback)

## TIP: LEARN FROM HISTORY

The multi-level feedback queue is an excellent example of a system that learns from the past to predict the future. Such approaches are common in operating systems (and many other places in Computer Science, including hardware branch predictors and caching algorithms). Such approaches work when jobs have phases of behavior and are thus predictable; of course, one must be careful with such techniques, as they can easily be wrong and drive a system to make worse decisions than they would have with no knowledge at all.

# 8.1 MLFQ: Basic Rules

## ■ MLFQ

### ✓ Basic structure

- 1) Consist of multiple queues
- 2) Each queue is assigned a different priority level
- 3) A job that is ready to run is on a single queue (running or blocked jobs are out of the queues)

### ✓ How to schedule?

- A job with higher priority (a job on a higher queue) is chosen to run next (RR among jobs in the same queue)
  - **Rule 1:** If  $\text{Priority}(A) > \text{Priority}(B)$ , A runs (B doesn't).
  - **Rule 2:** If  $\text{Priority}(A) = \text{Priority}(B)$ , A & B run in RR.

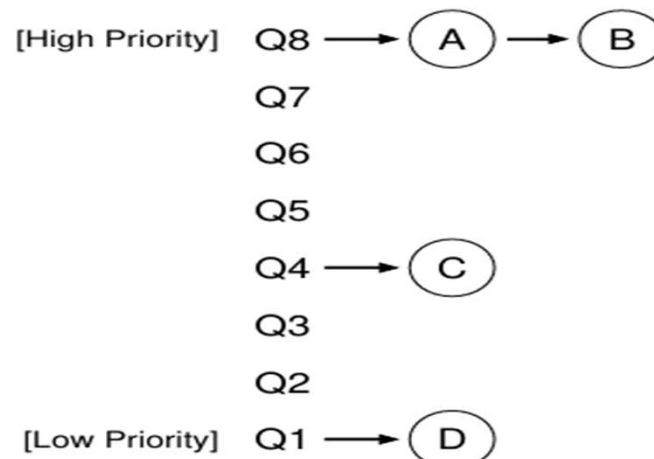

Figure 8.1: MLFQ Example

## 8.2 Attempt #1: How to Change Priority

### ■ How to assign a priority to each process?

- **Rule 3:** When a job enters the system, it is placed at the highest priority (the topmost queue).
- **Rule 4a:** If a job uses up an entire time slice while running, its priority is *reduced* (i.e., it moves down one queue).
- **Rule 4b:** If a job gives up the CPU before the time slice is up, it stays at the *same* priority level.

✓ Not fixed, change the priority of a job based on its observed behavior (**feedback**)

- Use CPU intensively → Next lower-level queue → Low priority
- Recently do I/Os → same queue → relative High priority
- Batch (low priority) vs. Interactive (high priority)

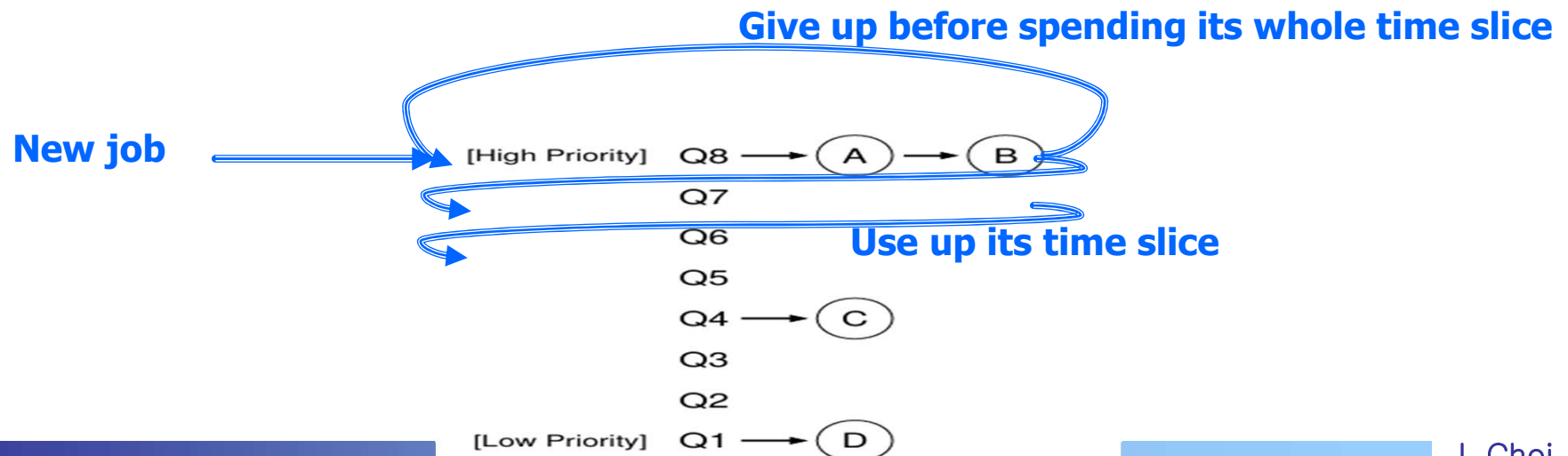

Figure 8.1: MLFQ Example

## 8.2 Attempt #1: How to Change Priority

### ■ Examples

- ✓ Example 1: A Single Long-Running Job → Fig. 8.2
  - Assumption: Three queues (Q2, Q1, Q0), one job, 10ms time slice
- ✓ Example 2: A long and a new arrived Job → Fig. 8.3 left
  - Just arrived job → MLFQ gives high priority (presumes as a short job)
    - Really a short job: run quickly and complete (approximates SJF)
    - If not: move down the queues, proving itself as a long-running
- ✓ Example 3: What about I/O? → Fig. 8.3 right
  - Assumption: two jobs, A: long-running job, B: short-intensive job
  - MLFQ keep a process at the same queue if it gives up CPU before using up its time slice (rule 4b)
    - Prefer I/O intensive job for good response time

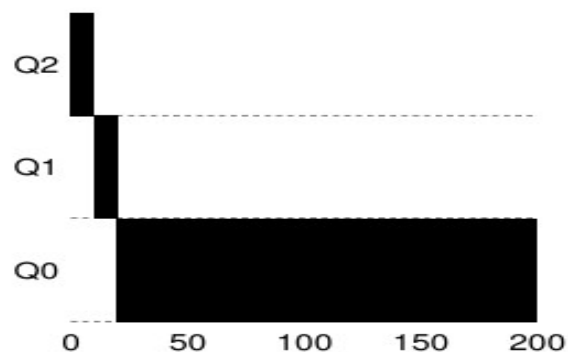

Figure 8.2: Long-running Job Over Time

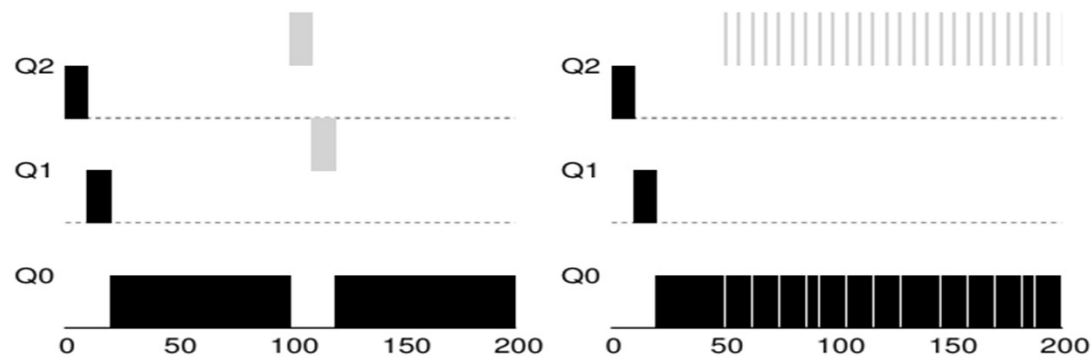

Figure 8.3: Along Came An Interactive Job: Two Examples

## 8.2 Attempt #1: How to Change Priority

---

### ■ Challenges with our current MLFQ

#### ✓ Pros of the current version

- Share CPU fairly among long-running jobs
- Allow short-running or I/O intensive jobs to run quickly

#### ✓ Issues

##### ▪ Starvation

- If there are “too many” interactive jobs, long-running jobs will never receive any CPU time (they starve)

##### ▪ User can trick the scheduler (game the scheduler)

- Just before the time slice over, issue an I/O request → remain in the same queue unfairly

##### ▪ A program may change its behavior

- CPU-intensive at the first phase → interactive at the later phase (e.g. service user request after long initialization)

## 8.3 Attempt #2: The Priority Boost

### ■ New rule for avoid starvation

#### ✓ One approach: periodic boosting

- **Rule 5:** After some time period  $S$ , move all the jobs in the system to the topmost queue.

#### ✓ Example

- Three jobs, two interactive jobs and one long-running job
- Priority boost every 50 ms

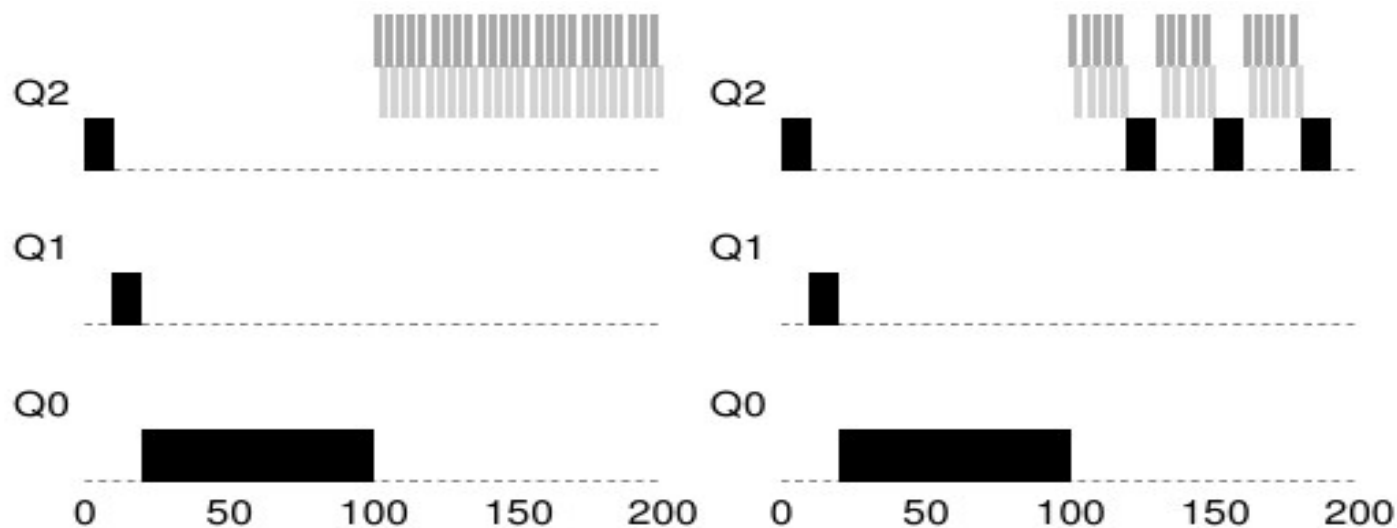

Figure 8.4: Without (Left) and With (Right) Priority Boost

## 8.4 Attempt #3: Better Accounting

- How to prevent gaming of MLFQ scheduler?
  - ✓ Change the rule 4a and 4b → instead of forgetting how much of a time slice a job used at a given queue, keep track it. Once a job has used its allotment, it is demoted to the next queue
  - **Rule 4:** Once a job uses up its time allotment at a given level (regardless of how many times it has given up the CPU), its priority is reduced (i.e., it moves down one queue).

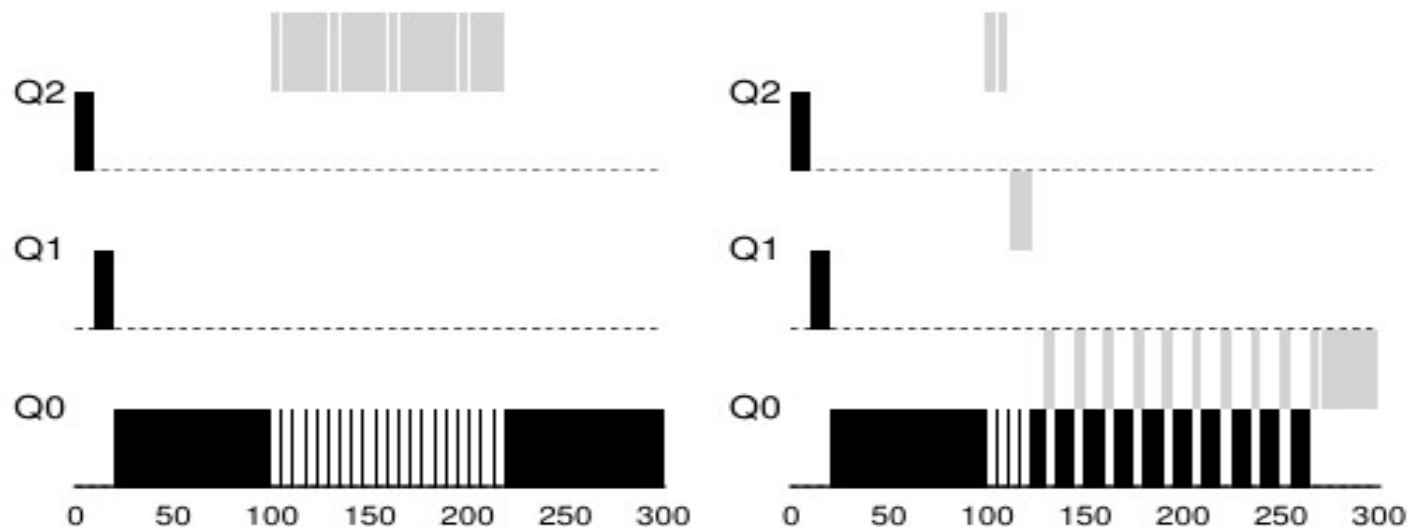

Figure 8.5: Without (Left) and With (Right) Gaming Tolerance

# 8.5 Tuning MLFQ and Other Issues

## ■ Parameters

### ✓ Issues

- How many queues?
- How big should the time slice be per queue? Same or Different?
- How often do the priority boost?

### ✓ Many MLFQ variants with diverse parameter settings

- Different time slice per queue: shorter for higher priority queue and vice versa (10, 20 and 40ms in Fig. 8.6 → can reduce context switch overhead)
- Solaris case: Table based
- BSD, Linux: Decay based (mathematical)
- Support user advice (e.g. nice system call)

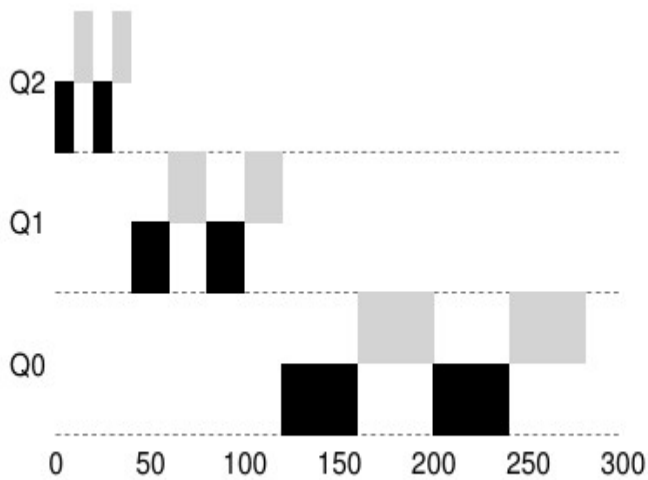

Figure 8.6: Lower Priority, Longer Quanta

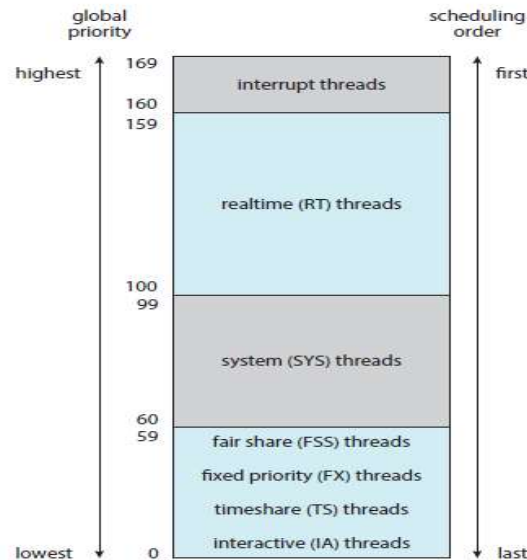

Figure 6.24 Solaris scheduling.

priority	time quantum	time quantum expired	return from sleep
0	200	0	50
5	200	0	50
10	160	0	51
15	160	5	51
20	120	10	52
25	120	15	52
30	80	20	53
35	80	25	54
40	40	30	55
45	40	35	56
50	40	40	58
55	40	45	58
59	20	49	59

(Source: A. Silberschatz, "Operating system Concept")

## 8.6 MLFQ: Summary

---

### ■ Name analysis

- ✓ Multi-level: multiple queues
- ✓ Feedback: based on history (track job's behavior over time and treat them accordingly)

### ■ Final rules

- **Rule 1:** If  $\text{Priority}(A) > \text{Priority}(B)$ , A runs (B doesn't).
- **Rule 2:** If  $\text{Priority}(A) = \text{Priority}(B)$ , A & B run in RR.
- **Rule 3:** When a job enters the system, it is placed at the highest priority (the topmost queue).
- **Rule 4:** Once a job uses up its time allotment at a given level (regardless of how many times it has given up the CPU), its priority is reduced (i.e., it moves down one queue).
- **Rule 5:** After some time period  $S$ , move all the jobs in the system to the topmost queue.

### ■ Features

- ✓ Try to good both for short-term interactive jobs and long-term batch jobs

# 8.6 Scheduling Comparison

- Workload: 5 processes (jobs)

Process	Arrival Time	Service Time
A	0	3
B	2	6
C	4	4
D	6	5
E	8	2

- Scheduling policies

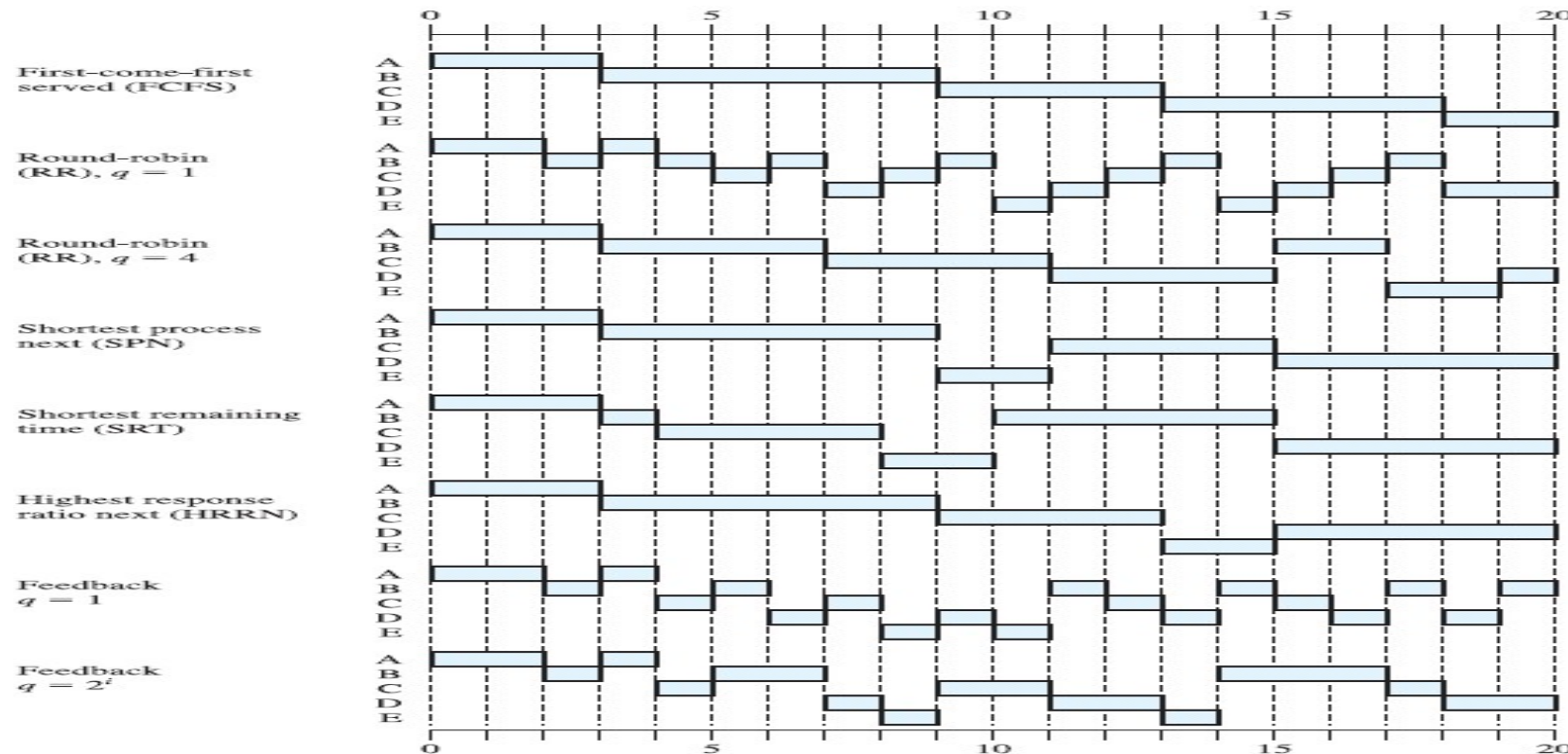

# Chap 9. Scheduling: Proportional Share

- Proportional Share (fair share)
  - ✓ Concept: instead of turnaround time or response time, it tries to guarantee that each job **obtain a certain percentage** of CPU time (especially important for **Cloud system**)
  - ✓ Scheduling algorithms: Lottery, Stride, ...

Example: 3 VMs A, B, C with 3 : 2 : 1 share ratio

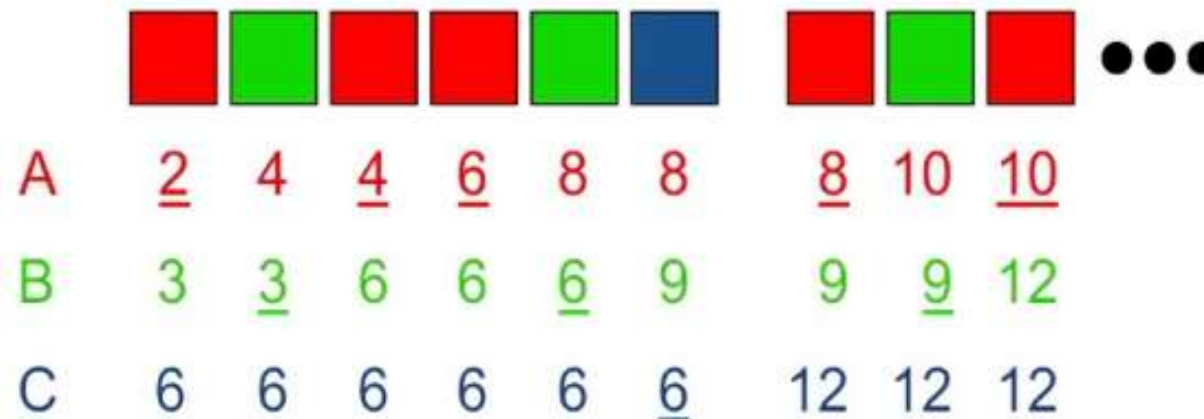

# 9.1 Basic Concept: Tickets Represent Your Share

## ■ Lottery scheduling

- ✓ Made by Waldspurger and Weihl
- ✓ Schedule a job who wins the lottery
- ✓ A job that has more tickets has more chance to win
  - Ticket: represent the share of a resource
  - Two jobs, A has 75% tickets while B has 25% tickets → win probability with 75% and 25% → 75% of CPU is expected to be used by A
- ✓ Example
  - Total tickets: 0~99, A: 0~74, B: 75~99

```
Here is an example output of a lottery scheduler's winning tickets:  
63 85 70 39 76 17 29 41 36 39 10 99 68 83 63 62 43 0 49 49  
  
Here is the resulting schedule:  
A      A  A      A  A  A  A  A  A  A  A  A      A      A  A  A  A  A  A  
      B          B          B      B
```

- 80% for A, 20% for B in this example (since it is based on probability). But, the longer it runs, the more likely it achieves the desired share

## 9.2 Ticket Mechanisms

### ■ Ticket currency

- ✓ Allow users to allocate tickets among their own jobs with correct global value
- ✓ Example
  - Two users, A: 100 tickets, B: 100 tickets
  - A has two jobs. A gives them each 500 tickets
  - B has only one job. B gives it 10 tickets
  - How many tickets are given into three jobs with a global viewpoint?

```
User A -> 500 (A's currency) to A1 -> 50 (global currency)
        -> 500 (A's currency) to A2 -> 50 (global currency)
User B -> 10 (B's currency) to B1 -> 100 (global currency)
```

### ■ Ticket transfer

- ✓ A job temporarily hands off its tickets to another job
- ✓ Especially useful in a [client/server environment](#)

### ■ Ticket inflation

- ✓ Temporarily raise or lower the # of tickets (in a cooperative env.)

# 9.3 Implementation

## ■ Benefit of Lottery scheduling

### ✓ 1. Simplicity

- All it needs are 1) random(), 2) counter and 3) ticket at each job

### ✓ Example

- Three job (see figure)
- Assume that we pick the number 300 → schedule C



```
1 // counter: used to track if we've found the winner yet
2 int counter = 0;
3
4 // winner: use some call to a random number generator to
5 //           get a value, between 0 and the total # of tickets
6 int winner = getrandom(0, totaltickets);
7
8 // current: use this to walk through the list of jobs
9 node_t *current = head;
10
11 // loop until the sum of ticket values is > the winner
12 while (current) {
13     counter = counter + current->tickets;
14     if (counter > winner)
15         break; // found the winner
16     current = current->next;
17 }
18 // 'current' is the winner: schedule it...
```

Figure 9.1: Lottery Scheduling Decision Code

# 9.4 An Example & 9.5 How to Assign Tickets?

## ■ Benefit of Lottery scheduling

### ✓ 2. Unfairness analysis

- Assumption: two jobs, same ticket, same run time (e.g.  $10\text{ms} * N$ )
- $U = C1/C2$ 
  - C1: Completion time of the earlier finished job
  - C2: Completion time of the later finished job
  - Implication (assume that  $N = 1$ )
    - $C1=10, C2=20 \rightarrow U = 0.5$  (worst fairness)
    - $C1=20, C2=20 \rightarrow U = 1$  (best fairness, ideal)
    - Long running  $\rightarrow$  Fig. 9.2

### ✓ How to assign tickets?

- Money  $\rightarrow$  Cloud computing
- Priority  $\rightarrow$  Soft RT system
- ...

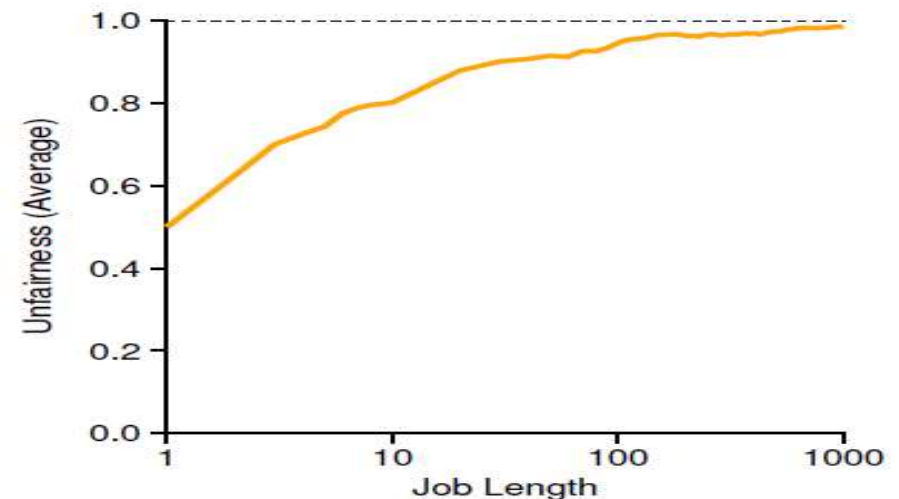

Figure 9.2: Lottery Fairness Study

## 9.6 Why Not Deterministic?

- Lottery scheduling
  - ✓ Not deterministic (rely on random number generator)
- Stride scheduling
  - ✓ A deterministic fair-share scheduler
    - Key concept: **Stride** → Inverse in proportion to the # of tickets
    - How to Schedule
      - Schedule a job who has the smallest pass value
      - Increment the pass value by its stride
  - ✓ Example
    - Three jobs: A, B, C, Tickets: 100, 50, 250
    - Stride: 100, 200 and 40 (divide 10000 by ticket)

Pass(A) (stride=100)	Pass(B) (stride=200)	Pass(C) (stride=40)	Who Runs?
0	0	0	A
100	0	0	B
100	200	0	C
100	200	40	C
100	200	80	C
100	200	120	A
200	200	120	C
200	200	160	C
200	200	200	...

Figure 9.3: Stride Scheduling: A Trace

# Chap. 10 Multiprocessor Scheduling (Advanced)

- Modern computer: Multicore (Dual or Quad or Octa or ...)
  - ✓ Commonly Hierarchical structure
    - Processor: chip or socket
    - Core: CPU unit is a chip
    - E.g.) 2 Processors + 2 cores a processor → 4 cores
  - ✓ Recent trends
    - Tens or hundreds of cores, Hyperthreading → **Manycore**
- For utilizing multicore effectively
  - ✓ Typical programs: serial program (use only one CPU) → make parallel program (e.g. using threads, Map/Reduce, ...)
  - ✓ Need a scheduler that can handle multiple CPUs → **load balancing**

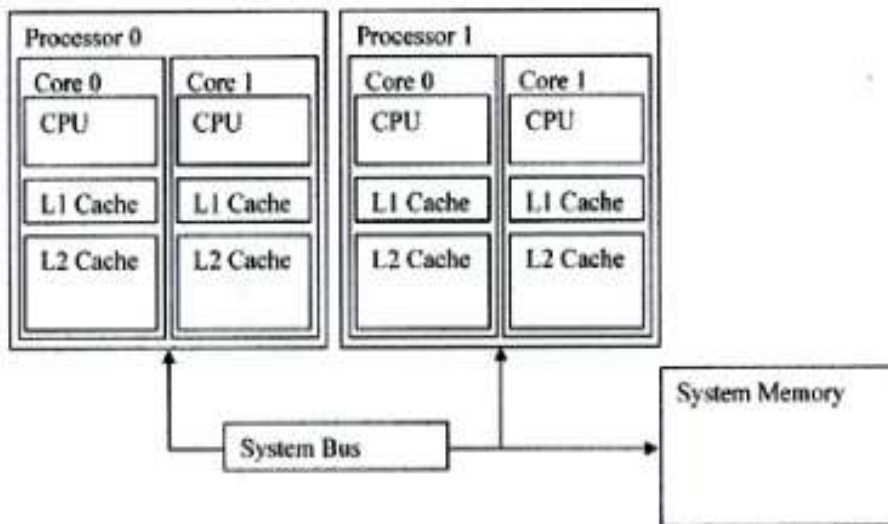

## ASIDE: ADVANCED CHAPTERS

Advanced chapters require material from a broad swath of the book to truly understand, while logically fitting into a section that is earlier than said set of prerequisite materials. For example, this chapter on multiprocessor scheduling makes much more sense if you've first read the middle piece on concurrency; however, it logically fits into the part of the book on virtualization (generally) and CPU scheduling (specifically). Thus, it is recommended such chapters be covered out of order; in this case, after the second piece of the book.

# 10.1 Background: Multiprocessor Architecture

- CPU cache (L1, L2, LLC)
  - ✓ Small, fast memory that generally hold copies of popular data (based on temporal and spatial locality)
    - Temporal locality: when a data is accessed, it is likely to be accessed again in the near future (e.g. stack, for loop, ...)
    - Spatial locality: when a data is accessed, it is likely to access data near as well (e.g. array, sequential execution, ...)
  - ✓ Benefit
    - **Cache hit**: make a program run fast by reducing access to the relatively slow main memory
    - **Delayed write**: modified data are kept in cache, not writing immediately into memory so that it possibly merges consecutive writes into a single memory access

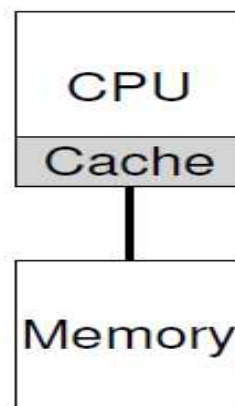

Figure 10.1: Single CPU With Cache

# 10.2 Synchronization & 10.3 Cache affinity

## ■ Issues on Multiprocessor

### ✓ Cache affinity

- When a process runs, it is often advantageous to run it on the same CPU where the process ran previously
- Since the CPU might build up a state in the cache (and TLB) for the process

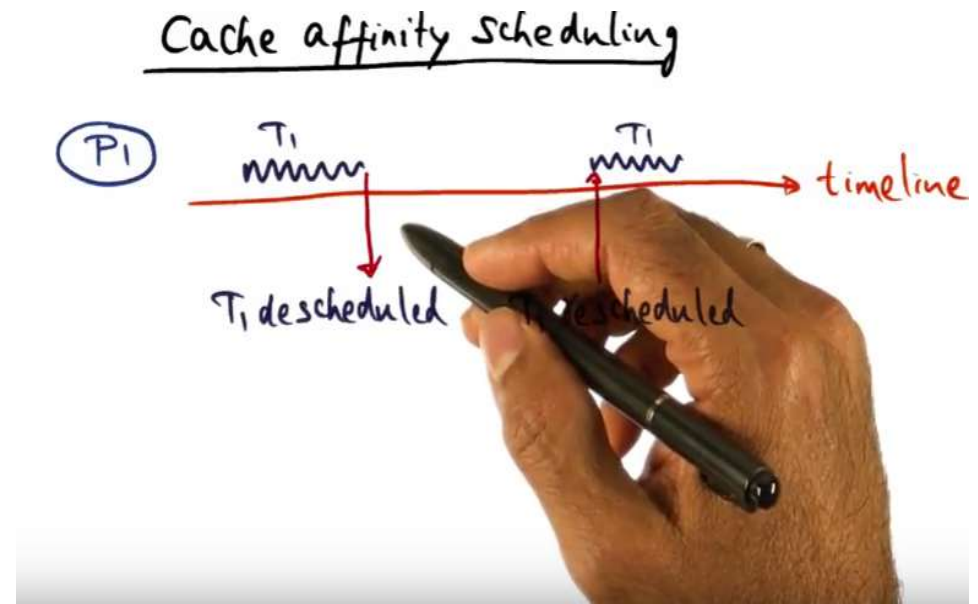
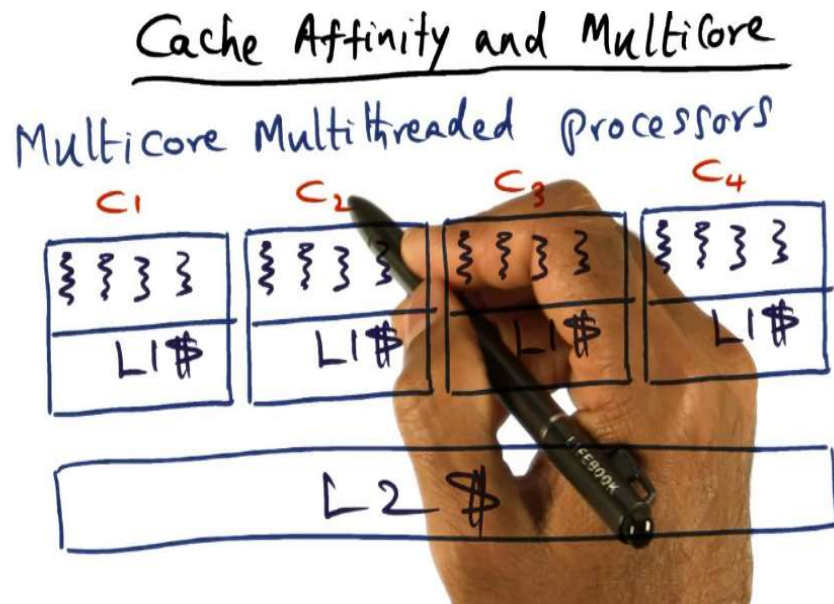

(Source: <https://www.youtube.com/watch?v=fSUqT4WpPdM>)

# 10.4 Single-Queue Scheduling

- SQMS (Single Queue Multiprocessor Scheduling)
  - ✓ Use the framework for single processor scheduling
  - ✓ Pros: simplicity
  - ✓ Cons: cache **affinity** (5 jobs and 4 CPUs example, need to some complex mechanism to support cache affinity to obtain the below right figure), **scalability** (especially due to lock for shared queue)

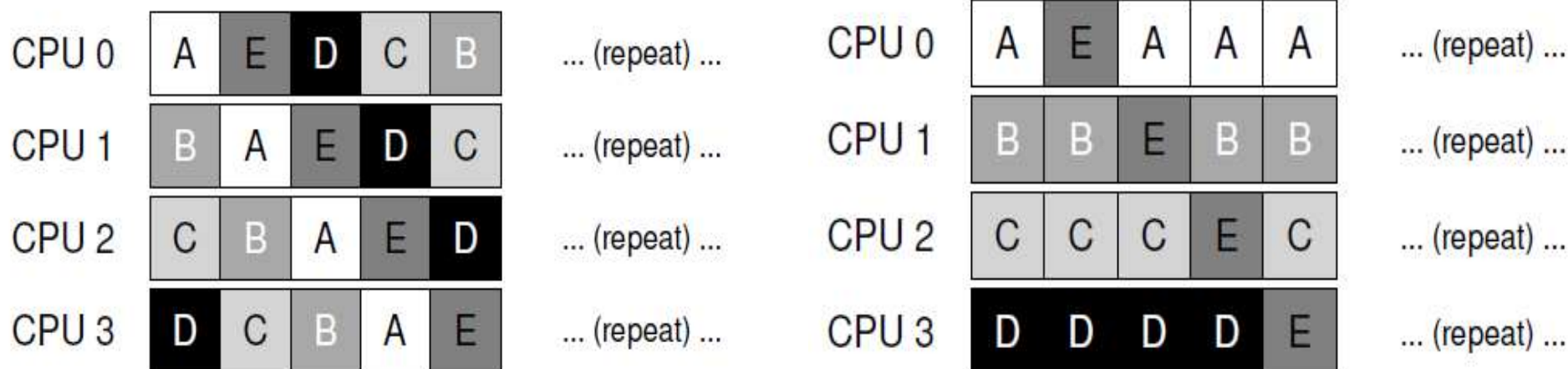
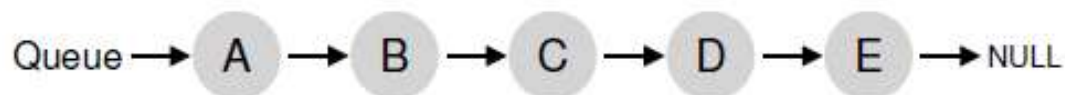

(without affinity consideration)

(with affinity consideration)

# 10.5 Multi-Queue Scheduling

- MQMS (Multi-Queue Multiprocessor Scheduling)

- ✓ Multiple queues, Jobs assigned a queue, Each queue is associated with a CPU (or a set of CPUs)
- ✓ Pros: cache affinity, less lock contention

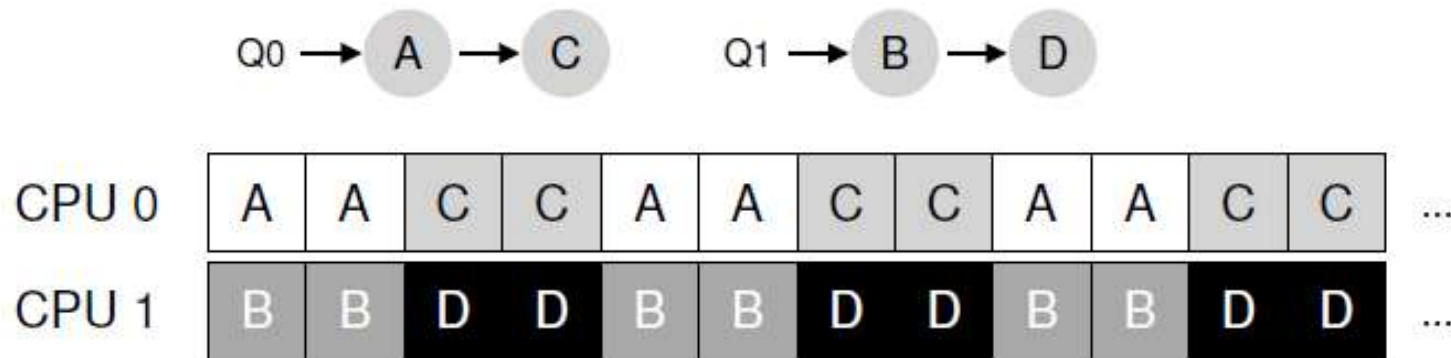

- ✓ Cons: need to consider **load balancing** (migration, work stealing)

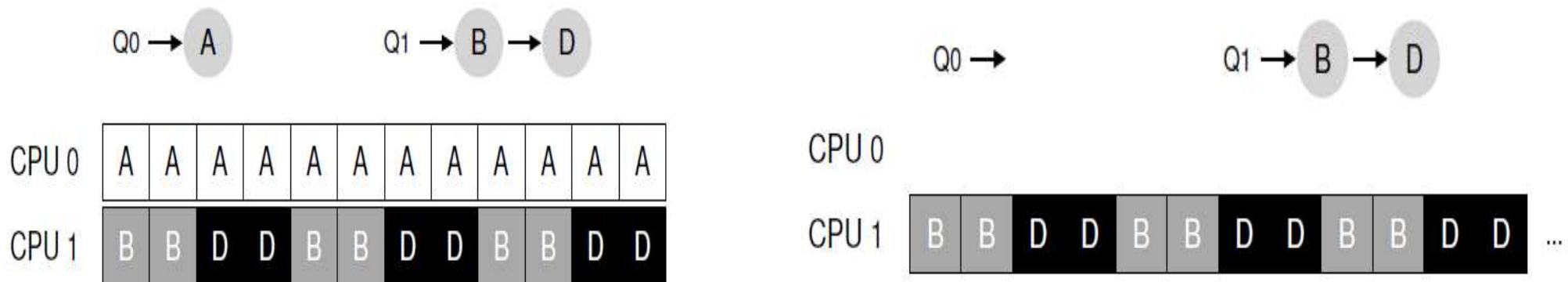

# 10.6 Linux Multiprocessor Schedulers (Optional)

- Two representative schedulers
  - ✓ O(1) scheduler
    - Multi-queue, similar to MLFQ (schedule higher priority, priority are changed dynamically)
  - ✓ CFS (Complete Fair Share Scheduler)
    - Multi-queue, similar to stride scheduling (deterministic proportional share scheduling)

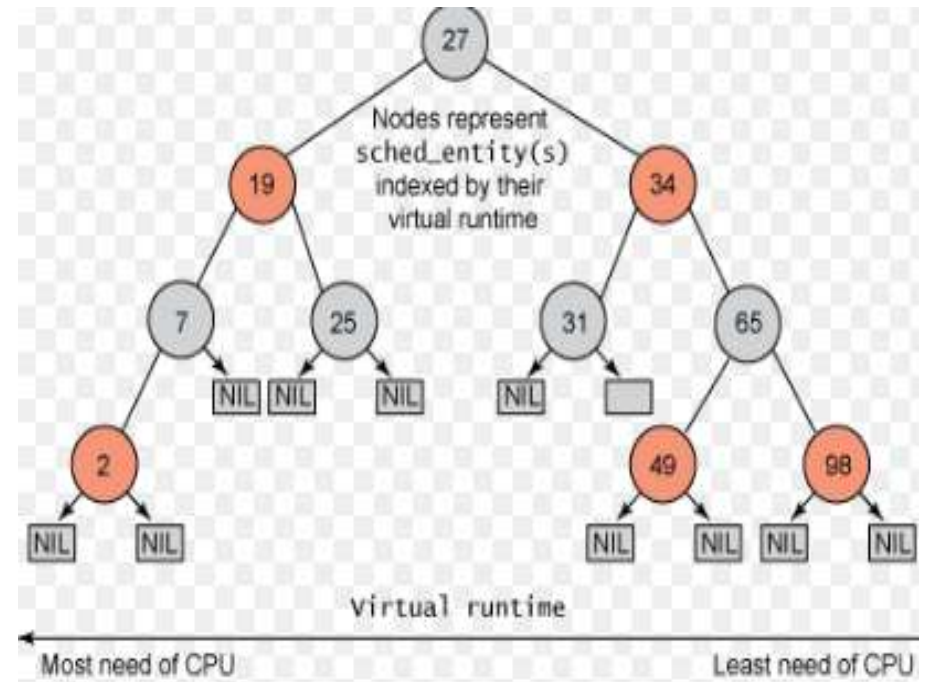
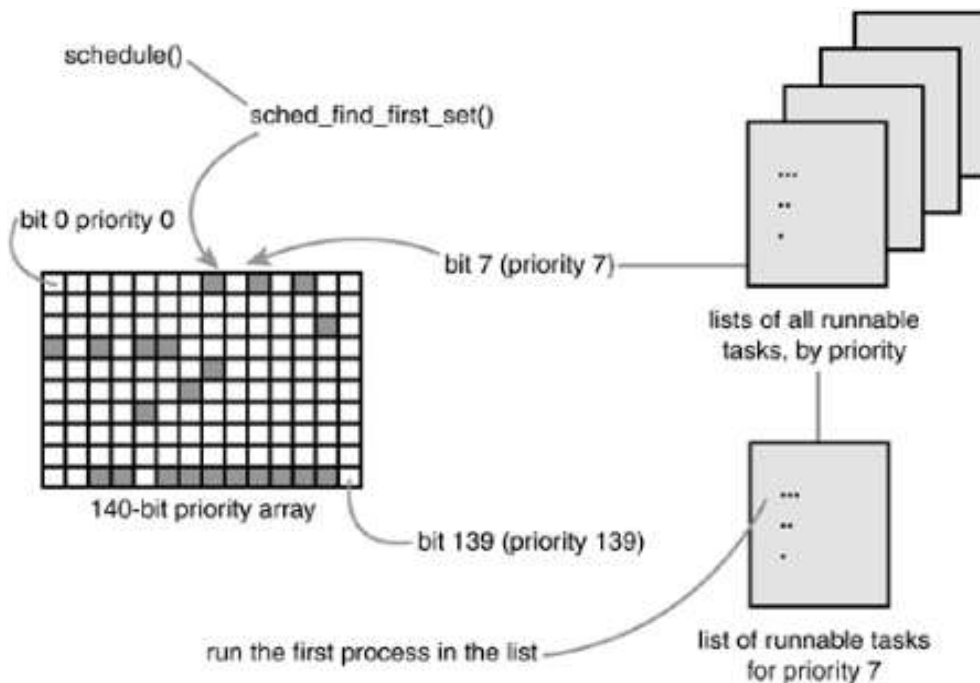

# Chap 11. Summary Dialogue on CPU virtualization

- What we have learned
  - ✓ Mechanism: Context switch, Limited Direct Execution, Interrupt,
  - ✓ Policy: FCFS, SJF, RR, MLFQ, Lottery, Stride, Multiprocessor, ...
- How to compare scheduling policies?
  - ✓ Analytic models: deterministic evaluation
  - ✓ Queueing theory: mathematical evaluation
  - ✓ Simulation: programming a model and executing it with real traces
  - ✓ Implementation: materialize as a real system

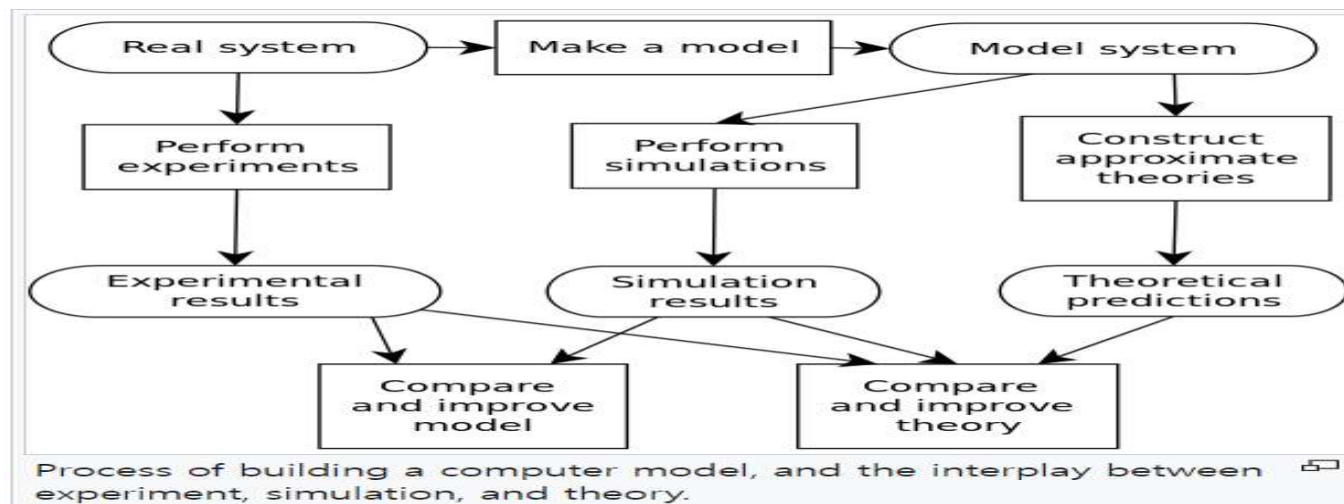

(Source: [https://en.wikipedia.org/wiki/Computer\\_simulation](https://en.wikipedia.org/wiki/Computer_simulation))

# Lab 1: Make a Scheduling Simulator

- What is Lab. project?
  - ✓ A programming project for demonstrating what you have learnt.
- What is the Lab. 1?
  - ✓ Goal: Make a scheduling simulator shown in Page 23.
    - Can configure different policies and workloads
    - See [Lab. 1](https://github.com/DKU-EmbeddedSystem-Lab/2026_DKU_OS) in [https://github.com/DKU-EmbeddedSystem-Lab/2026\\_DKU\\_OS](https://github.com/DKU-EmbeddedSystem-Lab/2026_DKU_OS)
  - ✓ How to submit?
    - Report + Source code (with Makefile)
      - Recommend structure for report: 1. Introduction (1.1 Goal, 1.2 How to?), 2. Design (2.1 Logical structure, 2.2 Key components), 3. Results (figures and tables), 4. Discussion, 5. Reference
    - **Upload at Google Form** or email to TA
  - ✓ Requirement
    - 1) policies: MLFQ, RR, FIFO, SJF (can be changed), 2) At least two execution results (one workload suggested by TA and different workloads chosen by you), 3) Environment: ubuntu on virtual box (See [Lab. 0](#) in the OS github), 4) Discussion is quite important!!, 5) Due: **two weeks later**.
  - ✓ Bonus
    - Lottery or Stride scheduling (note: we need different workloads)



# Quiz for this Lecture

## ■ Quiz

- ✓ 1. Discuss the differences between preemptive and non-preemptive scheduling. Give some examples from operating systems and real world.
- ✓ 2. Explain the differences between interactive and batch job. What scheduling policies are good for interactive or batch jobs?
- ✓ 3. Using the below left figure, explain what processes are in the ready queue (including order) at time 8.5 under the RR policy with the time quantum = 1 or 4.
- ✓ 4. We need to consider two things for multiprocessor scheduling. One is ( ) that tries to run a job on the same CPU where the process ran previously and the other is ( ) that tries to distribute jobs evenly among CPUs.
- ✓ 5. Discuss how does the stride policy schedule 3 VMs whose shares (tickets) are 2:3:5, respectively? (instead of 3:2:1 as in the right figure)

Process	Arrival Time	Service Time
A	0	3
B	2	6
C	4	4
D	6	5
E	8	2

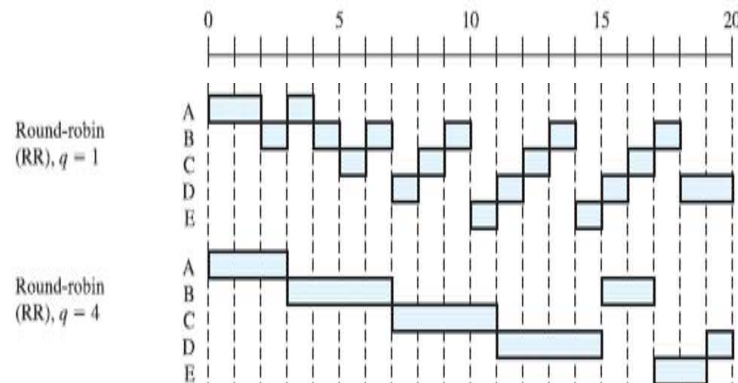

Example: 3 VMs A, B, C with 3 : 2 : 1 share ratio

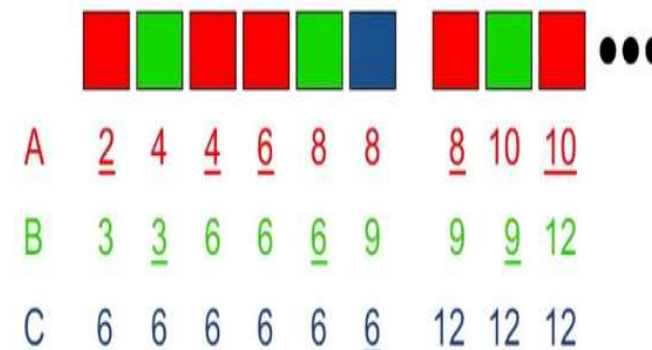

# Appendix 1: 7.9 No More Oracle

## ■ How to predict the length of a job (run time)?

- ✓ By user specification
- ✓ By prediction (approximation)
  - The CPU time length will be similar in length to the previous ones (characteristics of program behavior) → **exponential moving average**

$$\tau_{n+1} = \alpha t_n + (1 - \alpha)\tau_n.$$

- where
- ▷  $\tau_{n+1}$  = predicted value for the next CPU burst
  - ▷  $t_n$  = actual length of  $n^{\text{th}}$  CPU burst
  - ▷  $\alpha, 0 \leq \alpha \leq 1$

- Validation with  $\alpha = 0.5$  and  $\tau_0 = 10$  ( $\alpha$  determines the **weight** of each history)

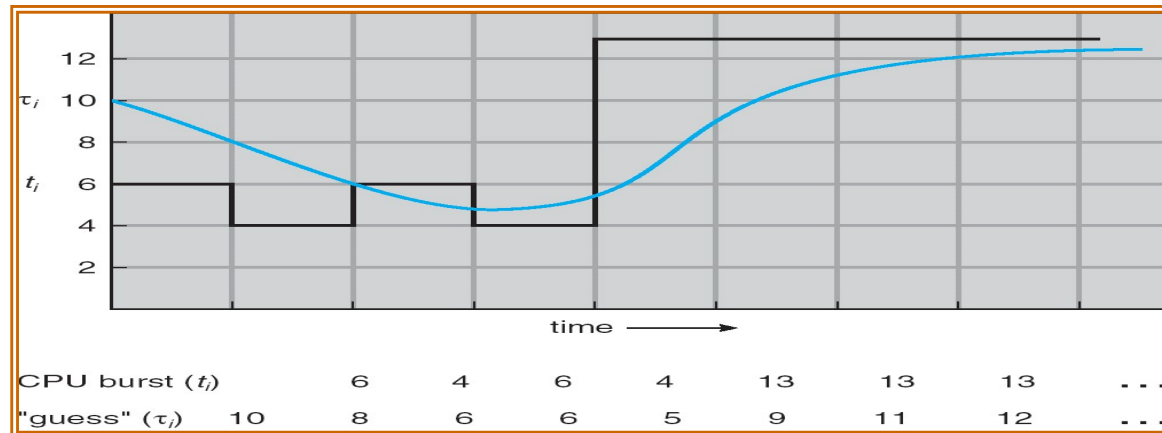

(Source: A. Silberschatz, "Operating system Concept")

# Appendix 1: Real time scheduling

- Task model:  $T_i (E_i, D_i, P_i, A_i)$ 
  - ✓  $E_i$ : execution time,  $D_i$ : Deadline
  - ✓  $P_i$ : period if periodic task,  $A_i$ : arrival time
- Scheduling algorithm
  - ✓ EDF (Earliest Deadline First)
    - Executes a job with the earliest deadline
  - ✓ RM (Rate Monotonic)
    - A task with a shorter period has a higher priority ( $D_i = P_i$  in general)

Task	Execution Time	Period	Priority
T1	1	4	High
T2	2	6	Medium
T3	3	12	Low

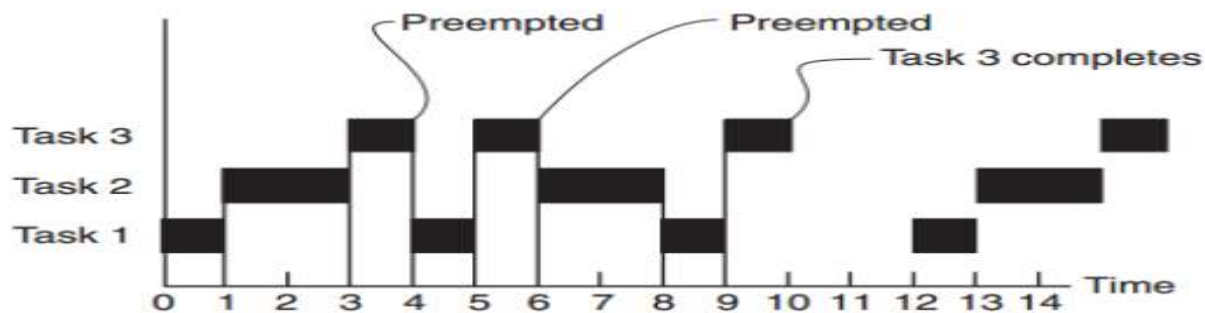

• What if T1 (2,4)?

Table 1: A scheduling problem from [1]  
Figure 1: "Critical instant" analysis, also from [1]

(Source: <https://www.eecs.umich.edu/courses/eecs473/Labs/Lab3F17.pdf>)

# Appendix 3: 10.1 Multiprocessor Architecture

- CPU cache is much complicated in Multiprocessor
  - ✓ Cache coherence: maintain coherence among caches
    - A program running on CPU1 reads data from address A
    - CPU1 fetches the data and keep it its cache (assume its value is D)
    - The program modifies D into D'. CPU1 applies the delayed write
    - OS decides to schedule the program into CPU2 (due to load balancing)
    - The program re-read the value from address A.
    - The value is the old one(D), not the correct one (D') → incoherent
  - ✓ Bus **snooping**: one of mechanisms for supporting coherence
    - Monitoring cache, Invalidate or update if data is modified

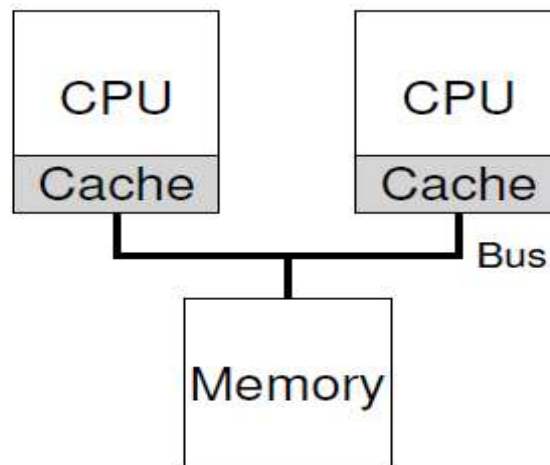

Figure 10.2: Two CPUs With Caches Sharing Memory

# Appendix 3: 10.2 Don't Forget Synchronization

## ■ Another issues

- ✓ Mutual exclusion on shared data
  - Imagine if programs on two CPUs enter the List\_Pop() routine at the same time
  - The first program executes line 9 while the second one executing line 8. What is the right content in the value (or head) variable?
  - May cause invalid pointer, double free, same value return, ...
- ✓ Synchronization such as locking is required for correctness

```
1  typedef struct __Node_t {
2      int          value;
3      struct __Node_t *next;
4  } Node_t;
5
6  int List_Pop() {
7      Node_t *tmp = head;          // remember old head ...
8      int value  = head->value;    // ... and its value
9      head      = head->next;     // advance head to next pointer
10     free(tmp);                  // free old head
11     return value;               // return value at head
12 }
```

Figure 10.3: Simple List Delete Code

# 사사

- 본 교재는 2026년도 과학기술정보통신부 및 정보통신기획평가원의 ‘SW중심대학사업’ 지원을 받아 제작 되었습니다.
- 본 결과물의 내용을 전재할 수 없으며, 인용(재사용)할 때에는 반드시 과학기술정보통신부와 정보통신기획평가원이 지원한 ‘SW중심대학’의 결과물이라는 출처를 밝혀야 합니다.

**IITP** 정보통신기획평가원  
디지털인재양성단 SW인재팀

